

---

**READ ALL INSTRUCTIONS BEFORE OPERATING EQUIPMENT**

User Manual for Models:

---

**DS1**

**DS1 K**

**DS1 V**

| Air Operated Pre-Mix Doorway  
Foam Unit |

---

**READ ALL INSTRUCTIONS BEFORE OPERATING EQUIPMENT**

**READ ALL INSTRUCTIONS BEFORE OPERATING EQUIPMENT**

**Specifications:**

Tubing .....25 feet polyethylene, 1/2 inch O.D.  
Foam output.....15 gallons/minute  
(56.78 liters/minute)  
Foam Pattern..... 5 foot wide X 9 foot in length  
(One nozzle assembly)

**Requirements:**

Compressed air 40 to 80 PSI (3 to 5 bar) with 3.5 to 8 CFM (99.15 to 226.62 l/min)  
Chemical requirements: follow all instructions from chemical manufacturer.  
Electrical requirement.....115VAC - 60HZ  
(GFI Protected Circuit)

**Air Operated Double Diaphragm Pump Options:**

P56.....Flojet polypropylene body with Santoprene diaphragm  
P56V..... Flojet polypropylene body with Viton diaphragm  
P56K..... Flojet polypropylene body with Kalrez diaphragm

**Acceptable Products:** Alkaline cleaners, Caustic cleaners, Sanitizers, and Acids.

\* D-Limonene and peracetic acid may only be used with Kalrez pump

\* Chlorine may only be used with Viton or Kalrez pump

**DO NOT USE: All hydrocarbons**

 **WARNING**

**Avoid Personal Injury**



1. Always wear protective clothing, gloves, and eye wear while servicing the foam unit.



2. Avoid contact of cleaning agent with skin and eyes. If contact occurs, see MSDS sheet for further first aid measures.



3. Follow safety instructions of chemical manufacturer (MSDS).

 **CAUTION**

**Avoid Equipment Damage**

1. Only use clean and dry air. Air must be filtered and free of moisture or pump life will be diminished. If needed, install air dryer before unit.

2. Do not use air lubricator before the unit.

3. Do not exceed a fluid temperature of 110°F (43°C).

READ ALL INSTRUCTIONS BEFORE OPERATING EQUIPMENT

Inside View - Control Box

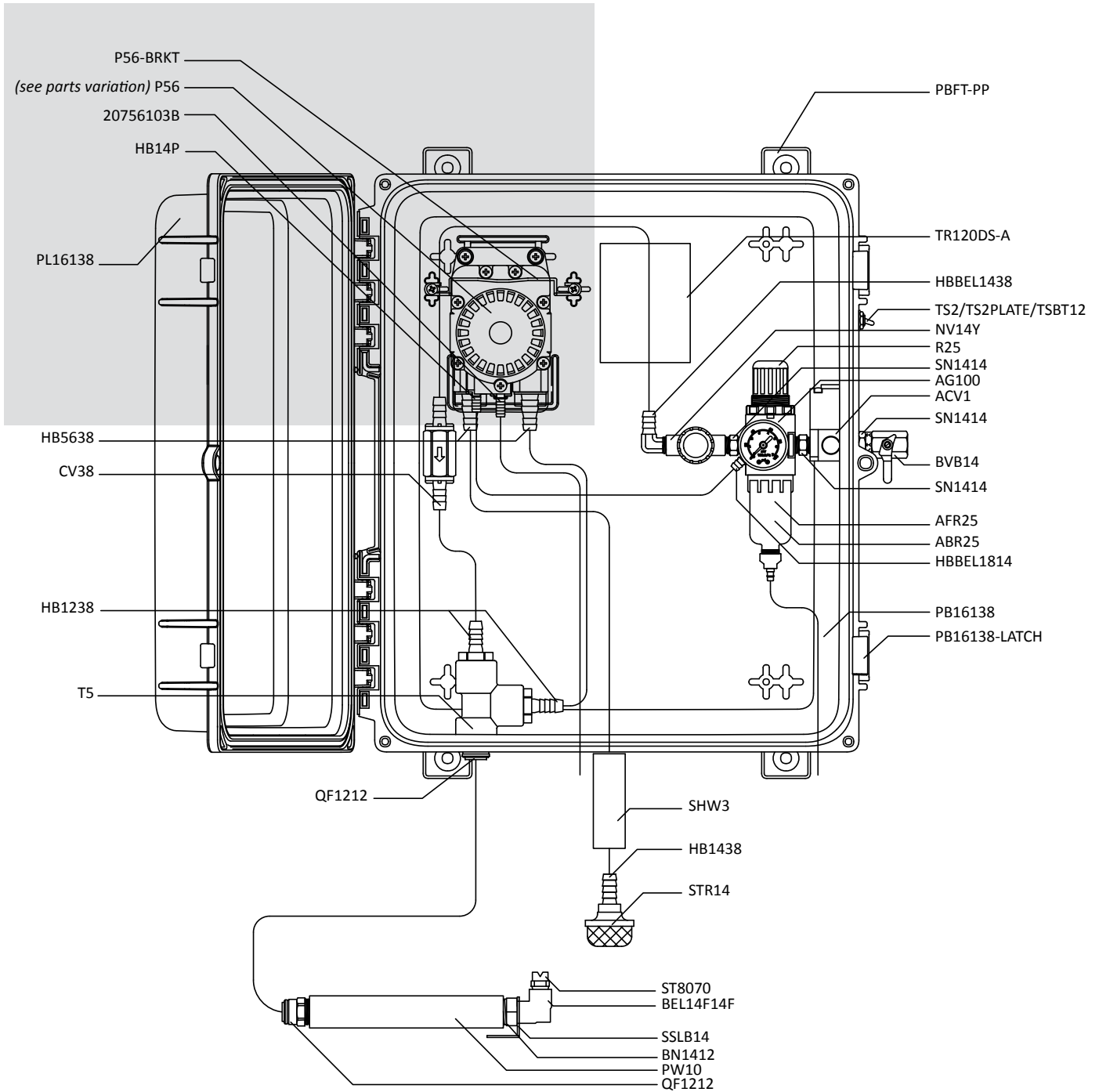

**READ ALL INSTRUCTIONS BEFORE OPERATING EQUIPMENT**

**Part Variations:**

Model: DS1  
Item Number: P56

Model: DS1 V  
Item Number: P56V

Model: DS1 K  
Item Number: P56K

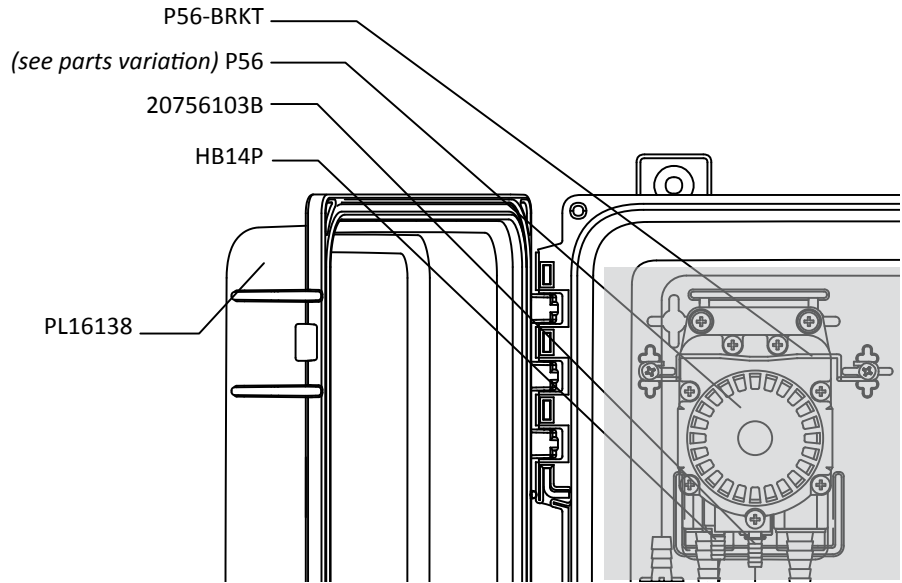

**READ ALL INSTRUCTIONS BEFORE OPERATING EQUIPMENT**

**Parts List**

ITEM NUMBER	DESCRIPTION
20756103B	Polypro G57 Air Port x HB Straight, w/ Viton o-ring
ABR25	METAL AIR BOWL for R25
ACV1	MAC VALVE 1/4in 110VAC
AFR25	AIR FILTER for R25
AG100	1.5in DRY MODEL 20 DUAL SCALE GAUGE
B10321	10-32 X 1 PHIL TRUSS MACH SCR 18-8
B10321.25	10-32 X 1 1/4 PHIL TRUSS MACH 18-8
BAG6X10	6 x 10 _ 4 mil recloseable bag 1000 / Case
BEL14F14F	BRASS ELBOW 1/4in FPT X 1/4in FPT
BN1412	BRASS HEX REDUCER NIPPLE 1/4in X 1/2in MPT
BVB14	AIR INLET VALVE - VA BRS 025-4F4F-BT, NICKEL
CC3224	LTC BLACK 1/2 NPT
CC8463	1/2in NPT BLACK LOCKNUT
CV38	PVC CHECK VALVE 3/8 BARBS - SS SPRING
EC14-2	OETIKER CLAMP 13.8
FWLG14	.569 ID X 1.28 OD X .08 THICK FLAT WASHER SS 18-8
H12C	1/2in CLEAR POLYVINYL TUBING
H12CP	1/2IN OD POLYETHYLENE TUBING - NATURAL
H14B-H	1/4 INCH BLUE HOSE- GOODYEAR HORIZON
H14B-H	1/4 INCH BLUE HOSE- GOODYEAR HORIZON
H38B-H	3/8 inch BLUE HOSE - GOODYEAR HORIZON
HB1238	1/2in MPT X 3/8in HOSE BARB
HB1438	1/4in MPT X 3/8in HOSE BARB (PLASTIC)
HB14P	1/4in BRASS HB AIR FITTING /G57/P56
HB5638	HOSE BARB FOR P56 PUMP
HBB1438	BRASS 1/4 MPT X 3/8 HOSE BARB
HBBEL1438	3/8 BRASS HOSE BARB X 1/4 PIPE ELB
HBBEL1814	1/8 MPT X 1/4 HOSE BARB BRASS 90DEG
NV14Y	FLOW CONTROL VALVE - INCLUDES BLACK KNOB
P56	5700 SANTO PUMP
P56-BRKT	PUMP BRACKET- STAINLESS STEEL
P56-BRKT-SCREW	HI LO SCREW FOR RETAINING P56-BRKT
P56K	5700 PUMP WITH KALREZ SEALS
P56V	FLOJET G57 PUMP WITH VITON
PB16138	POLYPROPYLENE CONTROL BOX - WORKING DIMS 16x13x8 - PUMP MOUNT
PB16138-GSKT	NEOPRENE GASKET 0.220 INCH ROUND CORD STOCK - 61.125 INCHES
PB16138-LATCH	LATCH FOR PB16138

PB16138-PIN	STAINLESS STEEL HINGE PIN FOR CONTROL BOX PB16138 - 1/8 x 4 3/4 x 1/2inches
PBFT-PP	MOUNTING FEET FOR POLYBOX - PB16138 - POLYPROPYLENE
PL16138	CONTROL BOX LID - POLYPROPYLENE - 16x13x8 - HINGED LOCKABLE LID
PW10	3/4in BLACK POLY PRO X 10in - FPTBE - SCH.80
QF1212	MALE CON. 1/2in TUBE X 1/2in MPT - POLYPROPYLENE
R25	AIR REGULATOR INCLUDES AIR FILTER AND BOWL
R25DT	CLEAR TUBING FOR R25 DRAIN
S1034FHL	10 X 3/4 PHIL FLAT HI-LO THRD SCREW 18-8
SHW3	3in LONG COATED WEIGHT
SN1414	STAINLESS 1/4" MPT X 1/4" MPT NIPPLE
SSC38	WORM GEAR CLAMP, S/S (.25-.63)
SSLB 14	14GA SS BRACKETS W/SLOTS
ST8070	VEEJET NOZZLE, BRASS 8070
STR14	40 MESH SUCTION LINE STRAINER 1/4 MNPT
T5	1/2 POLY TEE
TIE7.25	7.25in BLACK CABLE TIE
TR120DS-A	REPEAT CYCLE TIMER - ADJUSTABLE DIGI-SET - 120 VAC
TS2	TOGGLE SWITCH SPST
TS2PLATE	ON/OFF SWITCH PLATE
TSBT12	TOGGLE SWITCH BOOT
TW916	1/2 INT TOOTH L/W 410SS
WAAD-1X3	BROWN WADDING- 1" BY 3" DIE CUT
WCB14F	14-16 - 1/4 FEM INSULATED CONNECTOR
WMS14	14 X 1 1/4 HEX W/H SMS SLOTT, S/S
WMS14A	5/16 X 1 1/2 STRAIGHT PLASTIC ANCHOR
WR1A	18/3 SJOOV 90 BLACK N.A. W/ 5-15P & 7in ROJ

## READ ALL INSTRUCTIONS BEFORE OPERATING EQUIPMENT

### Installation Instructions:

1. Read all instructions before installing the foam unit.
2. Remove all parts from box.
3. Select desired area to mount the control box. It is recommended that the control box is to be mount on a vertical wall
4. Mount the control box using 4 of the screws and anchors provided. Note: When drilling holes for the plastic anchors provided with the screws, use a 5/16 inch drill bit.
5. Mount the spray tip assembly (GK6T) in the desired location using the stainless steel brackets (SSLB 14).
6. After the control box and nozzle assembly are mounted, run ½ inch tubing from the solution discharge (QF1212) to the nozzle assembly (GK6T).
7. Attach a compressed air line from an air compressor to the air inlet valve. Note: the air compressor needs to be able to maintain at least 4 cfm @ 60 psi (113.312 l/min @ 4.14 bar).
8. Set the timer (TR120DS-A). See timer specification and instructions below.
9. Make sure the toggle switch (TS2) is in the “OFF” position, and plug the unit into GFCI protected 110 VAC outlet.

### Operation Instructions:

1. Follow all instructions from chemical manufacturer.
2. Place suction line in pre-mixed solutions.
3. To activate the unit, turn the toggle switch (TS2) to the “ON” position.
4. If necessary, adjust the needle valve (NV14Y) to desired wetness or dryness of foam following the steps below:
  - a. Close needle valve (NV14Y) completely in clockwise direction.

- b. Open needle valve (NV14Y) in counter-clockwise direction 3 complete turns.
- c. Continue to open needle valve in ¼ turn increments allowing 30 seconds between adjustments until proper consistency of foam is achieved.

### Troubleshooting Instructions:

Check for proper air pressure on air gauge (AG100). The recommended air pressure is 50 to 60 psi (3.45 to 4.14 bar). The maximum air pressure is 90 psi (6.21 bar).

Check metal air bowl (ABR25) for debris such as water, oil, or rust particles. Clean by unthreading the air bowl (ABR25) from the air regulator (R25).

Check for plugged strainer (STR14). Replace strainer (STR14) if necessary. Strainer (STR14) must be used.

Make sure proper chemical and concentration is being used.

If the needle valve (NV14Y) is open too far the pump (P56) will cycle improperly due to lack of air pressure, if this occurs, reset needle valve (NV14Y) as described in operation instruction #4.

Make sure proper foaming chemical and concentration is being used.

If air passes through the pump (P56) without cycling, replace the pump (P56).

If foam solution backs up into the air bowl (ABR25), the check valve (CV38) needs to be replaced.

If foam comes out wet, no matter where the needle valve (NV14Y) is positioned, the check valve (CV38) may need to be replaced.

The TR120DS-A is an adjustable repeat cycle timer with the ON time operating first. ON and OFF times can range from 1 second to 511 minutes.

#### To set the timer:

1. Starting with the OFF time, move the top dip switch to the left for MIN (minutes) or to the right for SEC (seconds) to select the desired time interval.
2. The next 9 dip switches will be used to control the total active time. To the left is active and to the right is inactive. Combine the numbers of active dip switches to achieve the desired time. The increments are 1, 2, 4, 8, 16, 32, 64, 128, 256.
3. Repeat the above steps for the ON time setting.
4. Timer indicator light will appear red when unit output is off. The indicator turns green when output is on.

