USER MANUAL

**MODEL NUMBER:
FI-25N-SM
FI-25NK-SM
FI-25NV-SM
AND RELATED UNITS**

25 Gallon Smart Foam Unit

English (Original Instructions)

READ ALL INSTRUCTIONS BEFORE OPERATING EQUIPMENT



Read this manual completely and understand the machine before operating or servicing it.

- Read all instructions before installing or operating unit.
- Always wear appropriate personal protective equipment (PPE) when operating or servicing unit.
- Always follow all chemical safety precautions and handling instructions provided by the chemical manufacturer and Safety Data Sheet (SDS).
- If this unit is modified or serviced with parts not listed in this manual, the unit may not operate correctly.
- Never point the discharge wand at yourself, another person, or any object you do not want covered in chemical.
- Always keep the air trigger port clean and free of blockages or debris. If the port becomes dirty or blocked, disconnect the compressed air source from the unit immediately and clean out the port before proceeding.
- Always keep the discharge hose free of kinks or obstructions.
- Always rinse and drain unit after use (as described in the After Use Instructions). Always store unit disconnected from the compressed air source.
- Do not exceed an incoming air pressure of 100 psi (7 bar).
- Do not exceed a fluid temperature of 100°F (37°C).
- Always flush the unit with fresh water for 5 minutes when switching from an alkaline to an acid or an acid to an alkaline.
- Only use clean and dry air. Air must be filtered and free of moisture or pump life will be diminished. If needed, install a water separator (WS-20CFM) before the unit.
- Do not use an air lubricator before the unit.

PROTECT THE ENVIRONMENT

Please dispose of packaging materials, old machine components, and hazardous fluids in an environmentally safe way according to local waste disposal regulations.



Always remember to recycle.

*Specifications and parts are subject to change without notice.

OPTIONS		
	Pump Seal Material	
FI-25N	Santoprene (standard)	-SM
	Viton (V)	
	Kalrez (K)	
Add bold option codes to item number as shown. For standard options, no option code is needed. Examples: <ul style="list-style-type: none"> • FI-25N-SM (standard unit with Santoprene pump seals) • FI-25NV-SM (unit with Viton pump seals) 		

READ ALL INSTRUCTIONS BEFORE OPERATING EQUIPMENT

REQUIREMENTS	
Compressed air requirements	40-80 psi (3-5 bar) with 5-10 cfm (141-283 l/min)
Liquid temperature range	40-100°F (4.4-37°C)
Chemical compatibility	Chemical products used with this equipment must be formulated for this type of application and compatible with unit materials and pump seals. For more information on chemical compatibility, consult the manufacturer or SDS for your product or contact our customer service department.

SPECIFICATIONS	
Power type	Compressed air
Chemical pickup type	Draws from pre-mixed solution
Number of products unit can draw from	One product
Capacity	25 gallons (110.12 liters)
Discharge hose diameter/length	30 ft. (9.1 m) bonded hose, with 5/8 in. (15.9 mm) and 1/4 in. (6.4 mm) inside diameter
Discharge wand/tip type	Ultra high molecular weight (UHMW) polyethylene handle and wand extension, with 65 fan tip and built-in zero tip
Output distance	With zero tip: 17-21 ft. (5.2 m – 6.4 m) With fan tip (ST65150): 16-20 ft. (4.9 m – 6.1 m)
Output volume	With zero tip: 20-32 gal/min (75-121 l/min) of foam With fan tip (ST65150): 20-32 gal/min (75-121 l/min) of foam
Flow rate*	2 gal/min (7.6 l/min)
Pump seals	Santoprene, Viton, or Kalrez
Wheel type	Two 10 inch non-marking wheels

*Dilution rates and flow rates given are based on chemical with viscosity of water and factory air pressure settings.

READ ALL INSTRUCTIONS BEFORE OPERATING EQUIPMENT

Operation Instructions:

1. Verify that the drain plug (DP-A) is securely closed.
2. Follow all instructions from the chemical manufacturer. Fill the tank with water and the advised percentage of chemical concentrate.
3. Verify that the valve (PVCV34FM) at the base of the suction line is open, to allow fluid into the suction line.
4. Verify that the air trigger port is clean and free of blockages or debris, and the discharge hose is not kinked or obstructed.
5. With the wand pointed in a safe direction, connect an air line to the air inlet fitting (AP25).
Note: When you connect the air line, listen for any sound from the unit. If you hear the pump activate and begin to cycle, disconnect the air line immediately. This indicates that there is a blockage or other problem somewhere in the system, which could cause the unit to activate spontaneously. The problem must be addressed before proceeding (see "Troubleshooting Instructions").
6. Place thumb over the air trigger to activate the unit and begin foaming.
7. While the unit is running and discharging product, adjust the needle valve (NV14Y) as needed to regulate the wetness or dryness of the foam following the steps below:
 - a. Close needle valve completely in clockwise direction.
 - b. Open needle valve in counter-clockwise direction 2 complete turns.
 - c. Continue to open needle valve in ¼ turn increments, allowing 30 seconds between adjustments, until desired consistency of foam is achieved.
8. Release the air trigger to stop foaming.
Note: When you release the air trigger, the unit will shut off and depressurize. Foam that is already in the discharge hose may seep out, but no more foam will be created until you cover the air trigger again.

After Use Instructions:

1. Open the drain plug (DP-A) and drain the unit tank.
2. Rinse the unit tank thoroughly with fresh water. Then replace the drain plug and fill the tank with fresh water.
3. Activate the unit and allow it to run for 2-4 minutes, or until all chemical has been flushed from the system.
4. Open the drain plug (DP-A) and drain any water remaining in the unit tank. Then replace and secure the drain plug.
5. Disconnect the air line from the air fitting (AP25).
6. Allow any liquid remaining in the discharge hose to drain out through the discharge wand before storing the unit.

Maintenance Instructions:

To keep your unit operating properly, periodically perform the following maintenance procedures:

Note: Before performing any maintenance, ensure that the unit has been disconnected from the air supply according to the "After Use Instructions." Also ensure that the unit tank is empty, and/or close the valve (PVCV34FM) at the base of the suction line to shut off the flow of liquid from the tank. Reopen the valve after maintenance is complete.

- Inspect the air pump (P56/P56K/P56V) for wear and leaks.
- Inspect all hoses for leaks or excessive wear. Make sure all hose clamps are in good condition and properly secured.
- Check the air trigger port on the handle for debris and clean as needed. When cleaning, be careful not to push debris into the port, as it may become lodged inside and create a blockage.
- Clean and replace the filter (AFR25) located within the air regulator (R25) as needed. Access the filter by unthreading the air regulator bowl (ABR25) from the air regulator (R25).
- Check the suction line and strainer (STR38-IL) for debris or blockages, and clean as needed.
- Drain your air compressor tank on a regular basis to help extend pump life. An air source with a high moisture content will accelerate pump wear. Note: If your air source has a high moisture content, you may wish to install a water separator (WS-20CFM) before the unit.

READ ALL INSTRUCTIONS BEFORE OPERATING EQUIPMENT

Troubleshooting Instructions:

- Check to ensure that the discharge hose is uncoiled properly, and that there are no kinks that could obstruct fluid flow.
- Check the suction line and strainer for debris or damage. Clean or replace as needed. To prevent damage to the unit, the strainer (STR38-IL) must always be used.
- If the pump is cycling but will not pull product, and the suction line is clear, make sure the valve (PVCV34FM) at the base of the suction line is open.
- Check the air regulator bowl (ABR25) and air filter (AFR25) for debris such as water, oil, or rust particles. Clean by unthreading the air regulator bowl (ABR25) from the air regulator (R25).
- If the needle valve (NV14Y) is open too far, the pump (P56/P56K/P56V) may cycle improperly due to lack of air pressure. If this occurs, close and readjust the needle valve (NV14Y) as described in the Operation Instructions.
- Make sure proper foaming chemical and concentration are being used.
- If air passes through the pump (P56/P56K/P56V) without cycling, the pump needs to be replaced.
- If solution backs up into the air regulator bowl (ABR25), the check valve (CV38) needs to be replaced.
- If foam comes out wet, no matter where the needle valve (NV14Y) is positioned, the check valve (CV38) may need to be replaced.
- Check for proper air pressure on the air gauge (AG100). The air regulator (R25) is factory set at 50 psi (3.4 bar). Operating range is 40 to 80 psi (3 to 5 bar) with 5 to 10 CFM (141.6 to 283.3 l/min).
- If the unit operates at a reduced pressure:
 1. Check the air compressor supplying the unit. If the pressure is less than 40 psi, turn the unit off until the compressor can catch up.
 2. If the air supply is 50 psi (3.4 bar) or above, check the air gauge (AG100), which should read near 50 psi (3.4 bar). If the air gauge reads more or less than 50 psi (3.4 bar), adjust the pressure by turning the knob on the top of the air regulator (R25).
 3. If the problem persists, the stainless steel mixing mesh (SS-MESH) inside the tee fitting (SST12HB38) could be plugged. Remove and clean the mesh following the instructions below:
 - a. Ensure that the unit has been flushed and disconnected from the air supply according to the "After Use Instructions." Also ensure that the unit tank is empty, and/or that the valve (PVCV34FM) at the base of the suction line is closed.
 - b. Remove the stainless hose barb (HBSS1258) from the tee fitting (SST12HB38).
- c. The stainless steel mixing mesh (SS-MESH) is located inside the tee fitting (SST12HB38). Remove the old mesh and the screen that holds it in place. If the mesh and screen are in good condition, they can be cleaned and re-used. If not, they should be replaced with new parts.
- d. Insert the new mesh (SS-MESH).
- e. Insert the new screen (SSST). Make sure it is seated securely, but not bent or deformed.
- f. Reconnect the hose barb (HBSS1258) to the tee fitting (SST12HB38). Attach the 5/8 inch hose to the hose barb (HBSS1258) and secure it with the screw band clamp (SSC58).
- g. If you found a lot of particles or blockages inside the mesh, check the suction line strainer (STR38-IL) to make sure it is in place and operating correctly.
- If the unit activates when the air trigger port is not covered:
 1. Verify that the air trigger port is clean and free of blockages or debris, and the discharge hose is not kinked or obstructed.
 2. If the problem persists, try bypassing the air trigger. To do this, disconnect the 1/4 inch hose from the wand. Point the wand in a safe direction and connect an air line to the unit. Then, use your thumb or finger to seal the open port of the 1/4 inch hose at the wand.
 - a. If the unit activates when you connect the air line, the valve block (SM-PV) may need to be replaced.
 - b. If the unit does not activate when you connect the air line, the hose or wand assembly may need to be replaced.
- If the unit does not activate when the air trigger port is covered:
 1. Confirm the incoming air supply is consistently 50 psi (3.4 bar) on the air gauge (AG100).
 2. If the problem persists, the valve block (SM-PV) may need to be replaced.

READ ALL INSTRUCTIONS BEFORE OPERATING EQUIPMENT

**TANK ASSEMBLY
ITEM NUMBER: TANK-20N-A**

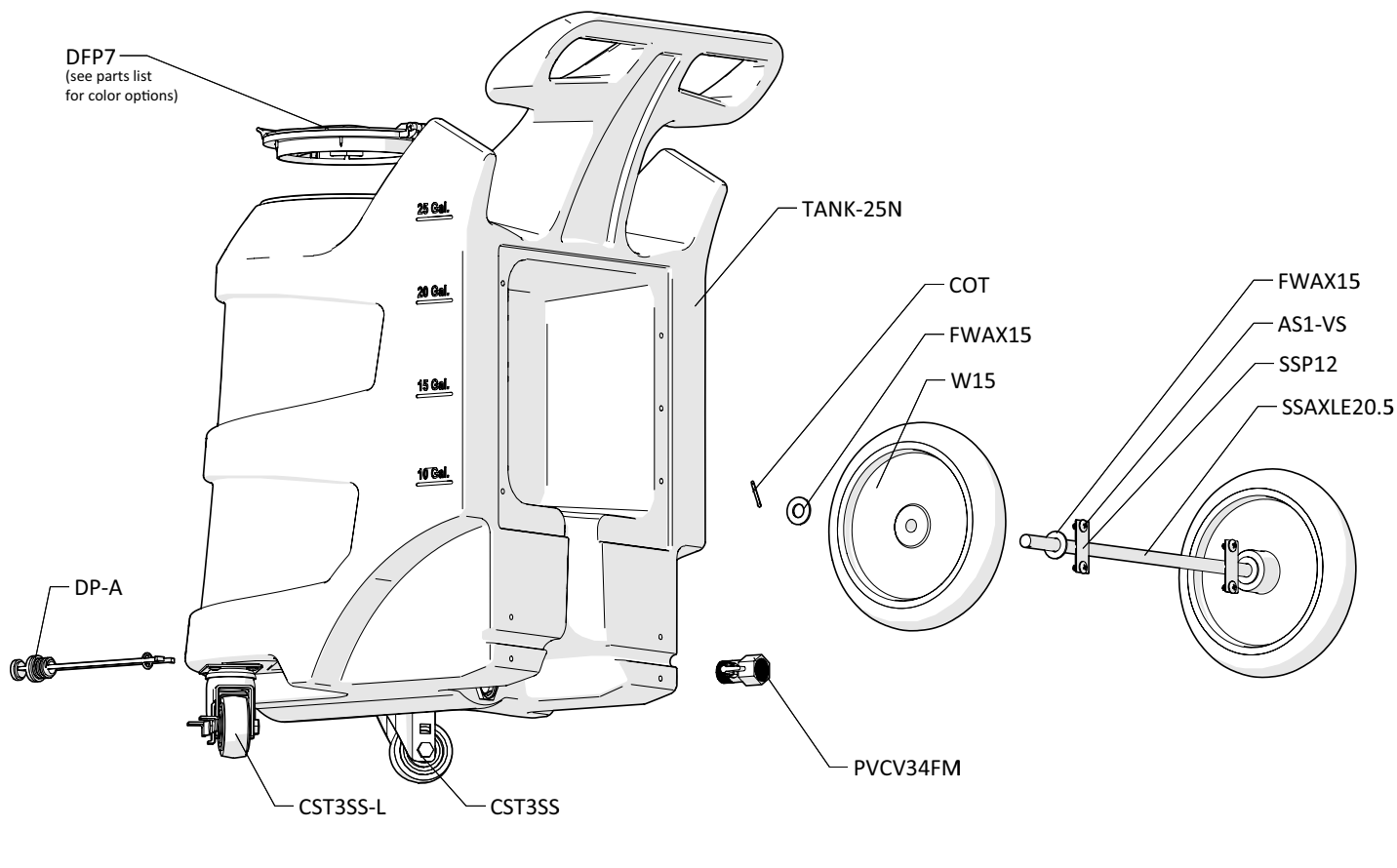

**WAND ASSEMBLY
ITEM NUMBER: SMWA**

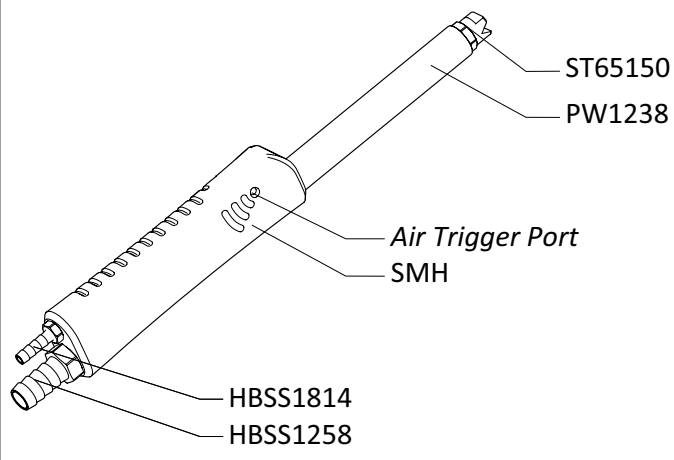

**DISCHARGE HOSE ASSEMBLY
ITEM NUMBER: H5814-30**

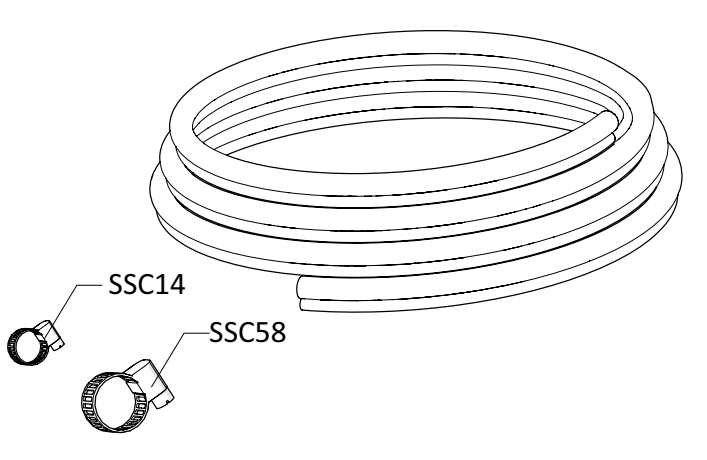

READ ALL INSTRUCTIONS BEFORE OPERATING EQUIPMENT

BACK PLATE

ITEM NUMBER: PA-PF-SM

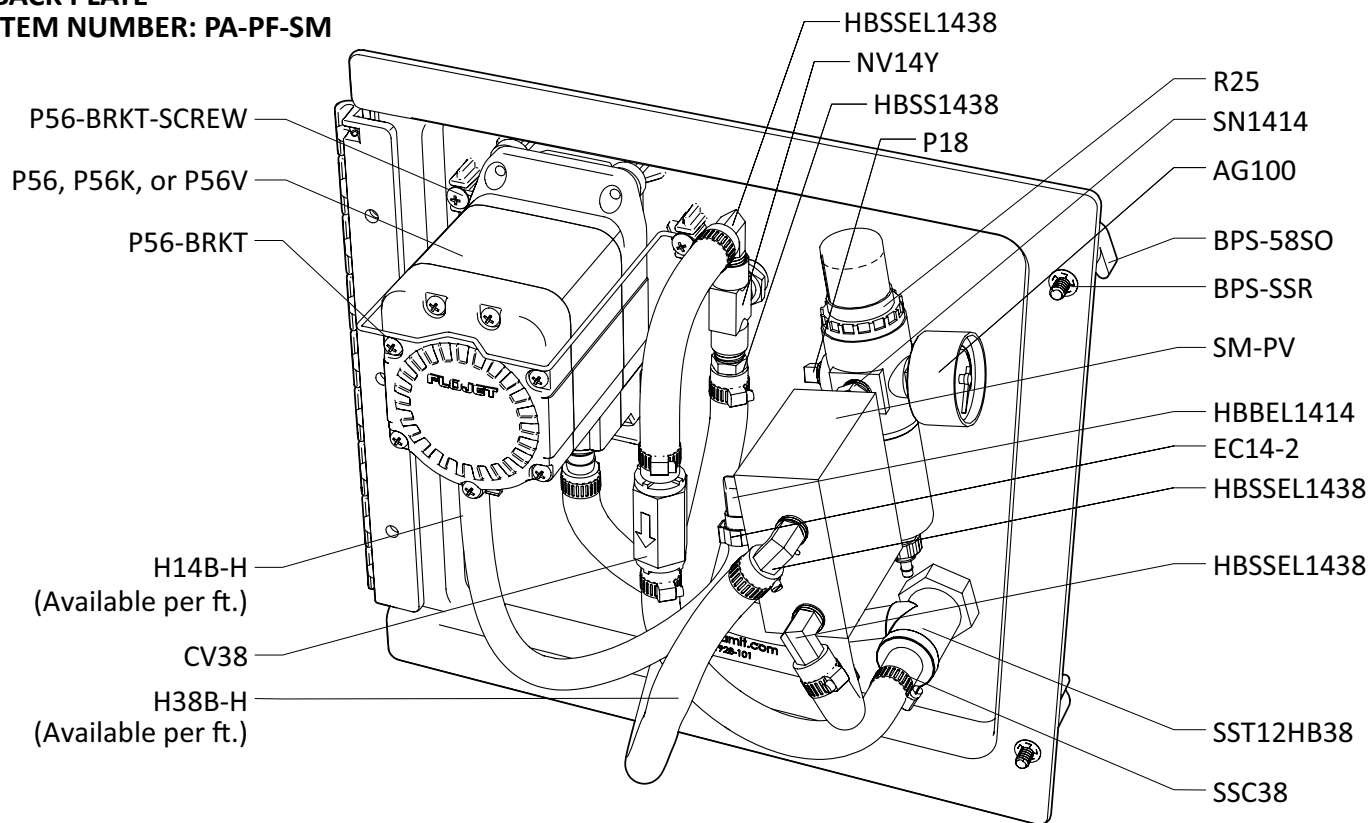

**BACK PLATE
Outside View**

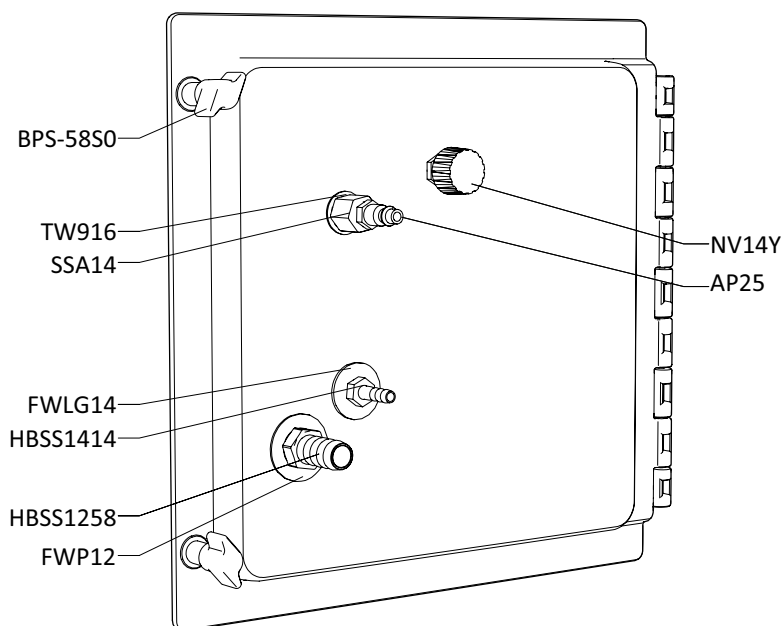

READ ALL INSTRUCTIONS BEFORE OPERATING EQUIPMENT

SUCTION LINE

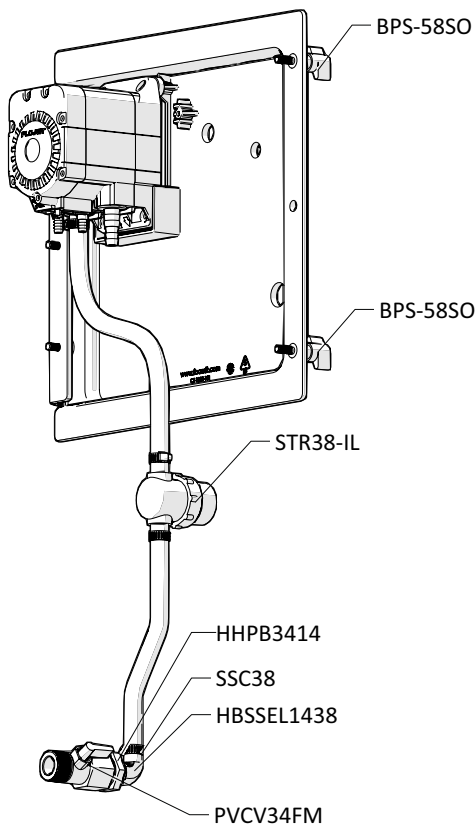

**OPTIONAL HOSE ATTACHMENT (INCLUDED)
ITEM NUMBER: SM-EA**

Installation Instructions

1. Remove wand (PW1238) from handle (SMH)
2. Thread HBSS1258 from hose attachment into handle (SMH)
3. Thread wand (PW1238) onto coupler (SC1212) at the end of hose attachment.

ITEM NUMBER	
EC58	OETIKER CLAMP 0.625 ID
H58-6	6 FT. OF 5/8 INCH BLUE HOSE
HBSS1258	STAINLESS STEEL HOSE BARB 1/2 MPT BY 5/8 INCH BARB
SC1212	S.S. COUPLER 1/2in BY 1/2in

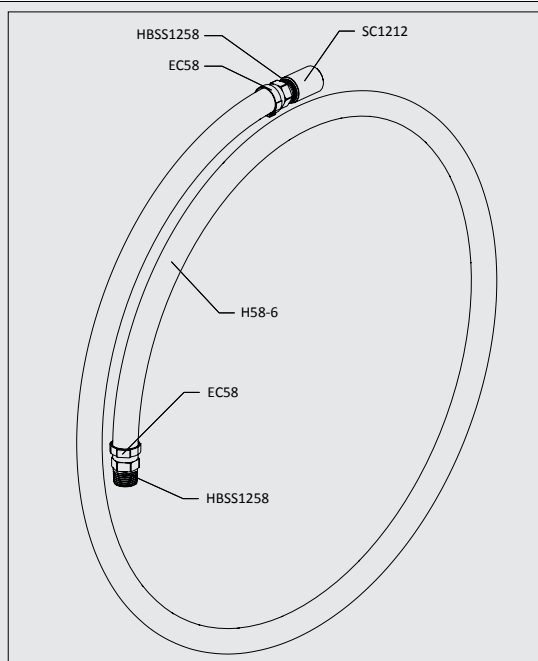

READ ALL INSTRUCTIONS BEFORE OPERATING EQUIPMENT

ITEM NUMBER	DESCRIPTION
AG100	1.5 INCH DRY MODEL 20 DUAL SCALE GAUGE
AP25	PLUG 1/4 NPTM AIR FITTING - BRASS
AS1-VS	1/4-20 X 1/2 PHIL TRUSS MACH SCREW 19-8 W/516 ORANGE VIBRASEAL PATCH
B8X58	8-15 x 1/2 FLAT PHIL TY-A 18-8 PLN
BPS-58SO	Back Panel Screw - 5/8 inch with Stand Off
BPS-SSR	1/4 INCH PUSHNUT BOLT RETAINER STAINLESS STEEL
COT	1/8 X 1 COTTER PIN 18-8 S/S
CV38	PVC CHECK VALVE 3/8 BARBS - SS SPRING
DFP7	7 INCH HINGED CAP ASSEMBLY - INCLUDES BLACK CAP, LID FLANGE AND HINGE PIN
<i>DFP7-C</i>	7 INCH FILL CAP POLYETHYLENE BLACK
<i>DFP7-F</i>	7 INCH TANK LID FLANGE POLYETHYLENE
<i>DFP7-PIN</i>	HINGE PIN FOR 7 INCH FILL CAP AND FLANGE
DFP7-C-BL	7 INCH FILL CAP POLYETHYLENE BLUE PANTONE
DFP7-C-GN	7 INCH FILL CAP POLYPRO GREEN PANTONE
DFP7-C-RD	7 INCH FILL CAP POLYPRO RED PANTONE
DFP7-C-YL	7 INCH FILL CAP POLYPRO YELLOW PANTONE
DP-A	DRAIN PLUG ASSEMBLY FOR NATURAL PORTABLE UNITS
<i>DP</i>	FRONT DRAIN PLUG FOR PORTABLE UNIT POLYETHYLENE
<i>DP-G</i>	FKM LATHE CUT 60 DUROMETER FKM
EC14-2	OETIKER CLAMP 13.8
EC58	OETIKER CLAMP 0.625 ID
FWAX15	FLAT AXLE WASHER
FWLG14	.569 ID X 1.28 OD X .08 THICK FLAT WASHER SS 18-8
FWP12	7/8 ID X 1.5 OD X 0.05 THK SSFW
H14B-H	1/4 INCH BLUE HOSE - Available per ft.
H38B-H	3/8 INCH BLUE HOSE - Available per ft.
H5814	BONDED HOSE 5/8in ID - 1/4in ID
H58-6	6 FT. OF 5/8 INCH BLUE HOSE
HBSS1258	STAINLESS STEEL HOSE BARB 1/2 MPT BY 5/8 INCH BARB
HBSS1414	HOSE BARB STAINLESS STEEL 1/4 MPT X 1/4 BARB
HBSS1438	STAINLESS HOSE BARB 1/4 MPT X 3/8 BARB
HBSS1814	1/8 MPT X 1/4 STAINLESS HOSE BARB
HBSS1438	STAINLESS HOSE BARB ELBOW 1/4 INCH NPT X 3/8 HOSE BARB
HHPB3414	HEX HEAD POLY REDUCER BUSHING 3/4 X 1/4
NV14Y	FLOW CONTROL VALVE - INCLUDES BLACK KNOB
<i>NV14Y-HNDL</i>	BLACK KNOB FOR NEEDLE VALVE - 2839-1/4
P18	PLUG 1/8 MPT HEX HEAD 304 SS
P56	PUMP WITH SANTOPRENE SEALS - INCLUDES HOSE BARBS, AIR FITTING, AND EXHAUST BARB

P56K	PUMP WITH KALREZ SEALS - INCLUDES HOSE BARBS, AIR FITTING, AND EXHAUST BARB
P56V	PUMP WITH VITON SEALS - INCLUDES HOSE BARBS, AIR FITTING, AND EXHAUST BARB
<i>20756103B</i>	Polypro G57 Air Port x HB Straight, w/ Viton o-ring
<i>HB14P</i>	1/4in BRASS HB AIR FITTING /G57/P56
<i>HB5638</i>	HOSE BARB FOR P56 PUMP
<i>HB5638K</i>	HOSE BARB FOR P56K PUMP
<i>HB5638V</i>	HOSE BARB FOR P56V PUMP
<i>P56-BRKT</i>	PUMP BRACKET- STAINLESS STEEL
<i>P56-BRKT-SCREW</i>	HI LO SCREW FOR RETAINING P56-BRKT
PLPF	PORTABLE FOAMER BACK PLATE W/ HINGE AND HOLES
PLPF-PIN	302 STAINLESS PORTABLE PLATE HINGE PIN
PVCV34FM	PVC VALVE 3/4in FPT X 3/4in MPT
PW1238	POLY WAND - 1/2 MPT X 3/8 FPT - UHMW
R25	AIR REGULATOR - 1/4fpt TWO PORT 1/8fpt TWO PORT - INCLUDES FILTER AND BOWL
<i>ABR25</i>	METAL AIR BOWL for R25
<i>AFR25</i>	AIR FILTER for R25
S142058-VS	1/4-20 X 5/8 PHIL TRUSS MACHINE SCREW 18-8 W/#516 VIBRASEAL ORANGE PATCH
SC1212	S.S. COUPLER 1/2in BY 1/2in
SM-PV	PNEUMATIC VALVE FOR SMART TECHNOLOGY UNITS
SMH	HANDLE FOR BONDED HOSE - 1/2in FPT AND 1/8in FPT - UHMW
SN1414	STAINLESS 1/4MPT X 1/4MPT NIPPLE
SSA14	SS304 MALE/FEMALE ADAPTOR 1/4 NPT X 1/4 NPT
SSAXLE20.5	STAINLESS STEEL AXLE 20.5 INCHES LONG BY 5/8 INCH IN DIAMETER DRILLED AND BEVELED
SSC38	WORM GEAR CLAMP, S/S (.25-.63)
SSC58	WORM GEAR CLAMP, SS 5/8IN
SSMESH	STAINLESS STEEL MESH- 1 ball
SSP12	STAINLESS STEEL AXLE PLATE - 2.5 inch X 1 inch - 2 HOLE
SSST	SCREEN DISC .687 DIA. 10 X 10 MESH @ .020 DIA. 300 SERIES S.S.
SST12HB38	STAINLESS TEE COMBO 1/2in FPT X 3/8 in BARB WITH SSST AND S.S. MESH
<i>SS-MESH</i>	STAINLESS STEEL MESH WITH SSST FOR REPLACEMENT
<i>SSST</i>	SCREEN DISC .687 DIA. 10 X 10 MESH @ .020 DIA. 300 SERIES S.S.
ST65150	VEEJET NOZZLE 65150 - 3/8 MPT
STR38-IL	IN LINE STRAINER 3/8 BARB 20 MESH 304 STAINLESS EDPM GSKT
TANK-25N	25 GALLON TANK NATURAL IN COLOR
TW916	1/2 INT TOOTH L/W 410SS
W15	NONMARKING WHEEL FOR PORTABLE UNITS