

1.3 Gallon Pump-Up Foam Unit

User Manual

F5.0L | F5.0L-PSG

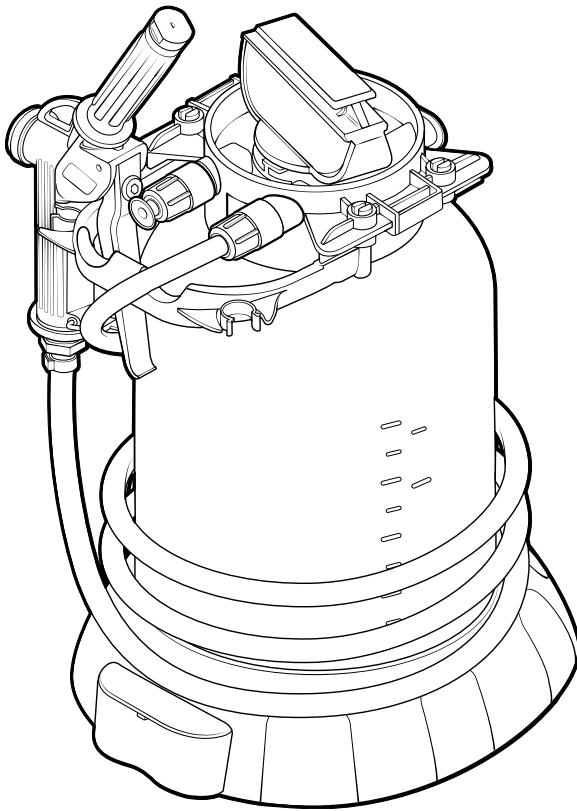

F5.0L-PSG

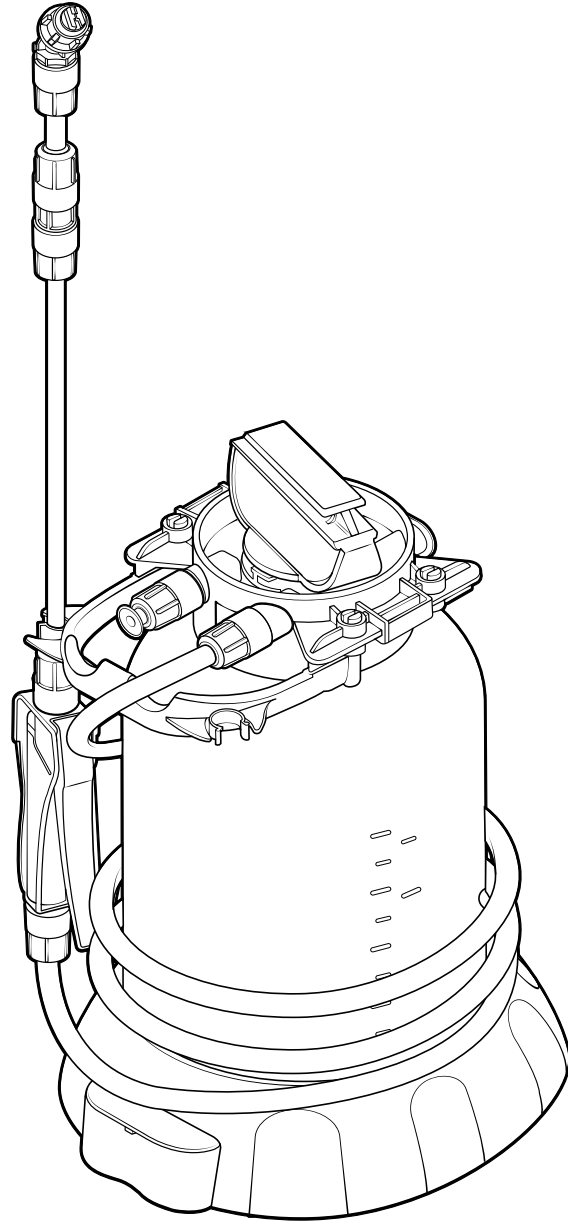

F5.0L

READ ALL INSTRUCTIONS BEFORE USING OR SERVICING THIS UNIT. KEEP THIS MANUAL IN A LOCATION THAT IS READILY AVAILABLE TO USERS AND SERVICE TECHNICIANS.

English (Original Instructions)



Scan this code
for user manual

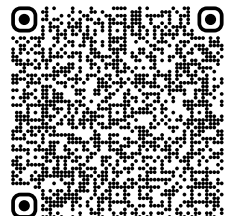

Safety

⚠ WARNING

PEOPLE OR OBJECTS CAN BE HURT OR DAMAGED IF THIS UNIT IS NOT USED CORRECTLY!



Failure to read all the instructions before operating the unit may result in personal injury or death from the improper use or the chemical solution. Anyone handling, operating or using the unit must read and understand the instructions in the manual. The buyer assumes all responsibility for safety and proper use in accordance with the instructions.



Using or servicing the unit without appropriate personal protective equipment (PPE) may result in serious injury such as burns, rashes, eye, throat or lung damage and death. Always wear PPE as indicated in the Safety Data Sheet (SDS) when using or servicing the unit. Protect eyes, skin, and lungs against drifting spray.



Chemical solutions may pose a health risk and death if they contact the skin or eyes, are inhaled or swallowed. Always read and follow all chemical safety precautions and handling instructions provided by the chemical manufacturer and the SDS associated with the chemical solution before using the unit.



Pressure within the equipment may cause an unexpected release of the chemical solution and cause serious injury such as burns, rashes, eye damage, throat or lung damage and death. Always depressurize and clean the unit after each use. Never leave the unit unattended while pressurized.

Using the unit with fluid temperatures above 100°F (37.8°C) may result in scalding, burns, serious injury or death. DO NOT use a solution with a temperature above 100°F (37.8°C).

Operating the unit when damaged or leaking may result in exposure to chemical solutions, serious injury or death. Never use the unit if it is damaged or leaking.

Never point the discharge wand at yourself, another person, or any object you do not want covered in chemical.



Use of hydrocarbons and flammable products may result in explosions, fire and serious injury or death. Never use hydrocarbons or flammable products with the unit.



Mixing an alkaline with an acid may result in a chemical reaction. Overheating of the mixture may cause it to splatter caustic compounds or release hazardous fumes, gas and vapors. Always flush the unit with fresh water thoroughly when switching from an alkaline to an acid or an acid to an alkaline.

NOTICE

Servicing, or modification, of this unit with parts not listed in this manual may cause the unit to operate improperly. Do not use unauthorized parts when servicing the unit.

Only lift and carry unit by the carrying handle. Do not lift or carry the unit by the pump handle, hose, wand, or other components.

Do not use unit while pump handle is extended or not fully locked into position

PROTECT THE ENVIRONMENT



Please dispose of packaging materials, old machine components, and hazardous fluids in an environmentally safe way according to local waste disposal regulations.

Product Overview

Requirements

Liquid temperature range	40-100°F (4.4-37.8°C)
Chemical compatibility	Chemical products used with this equipment must be formulated for this type of application and compatible with unit materials and pump seals. For more information on chemical compatibility, consult the manufacturer or SDS for your product or contact our customer service department.

Specifications

	F5.0L	F5.0L-PSG
Power type	Manual	
Chemical pickup type	Draws from pre-mixed solution	
Number of products unit can draw from	One product	
Suction line length/diameter	11.5 in. (29.2 cm) clear poly tubing with 1/8 in. (3.2 mm) inner diameter	
Capacity	1.3 gallons (5 liters)	
Discharge line length/diameter	6.5 ft. (2 m) hose, with 1/4 in. (6.4 mm) inside diameter	
Discharge wand/tip type	Polypropylene trigger handle with 17 in. (43.2 cm) wand extension and 110° fan tip	Polypropylene trigger handle with 65° fan tip
Output distance*	1-3 ft. (0.3-0.9 m)	3-5 ft. (0.9-1.5 m)
Output volume*	1 gal/min (3.8 l/min)	2.5 gal/min (9.5 l/min)
Flow rate*	0.2 gal/min (0.8 l/min)	0.5 gal/min (1.9 l/min)
Pump seals	Viton	

*Rates given are based on chemical with viscosity of water and factory air pressure settings. These rates can vary based on viscosity of product and fan tip size.

Product Components

Get to know the components that you will need to use, adjust or assemble.

Pump-Up Foam Unit • 1.3 Gallon

1. Discharge wand
2. Trigger gun
3. Pressure relief valve
4. Discharge hose
5. Pump handle
6. Tank head
7. Solution tank

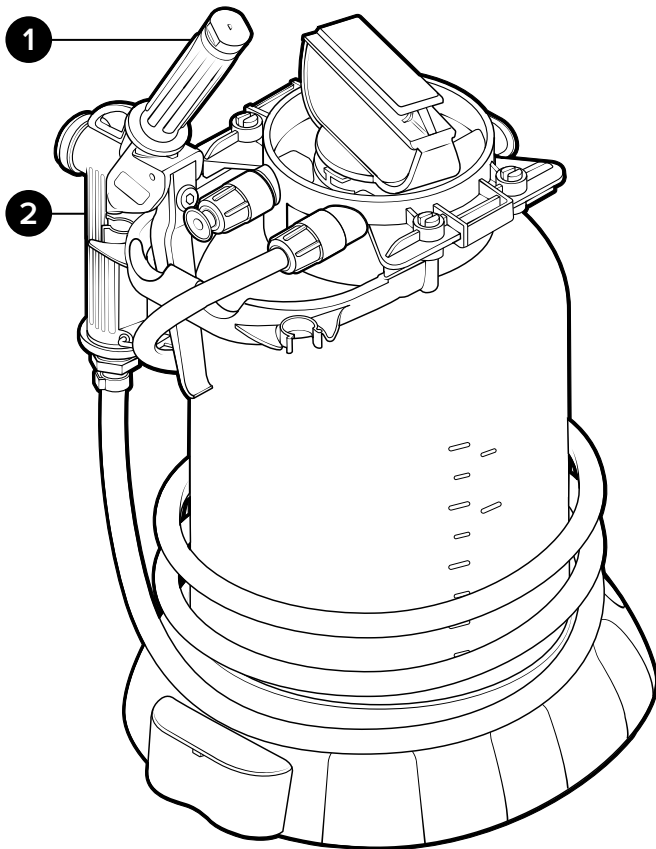

F5.0L-PSG

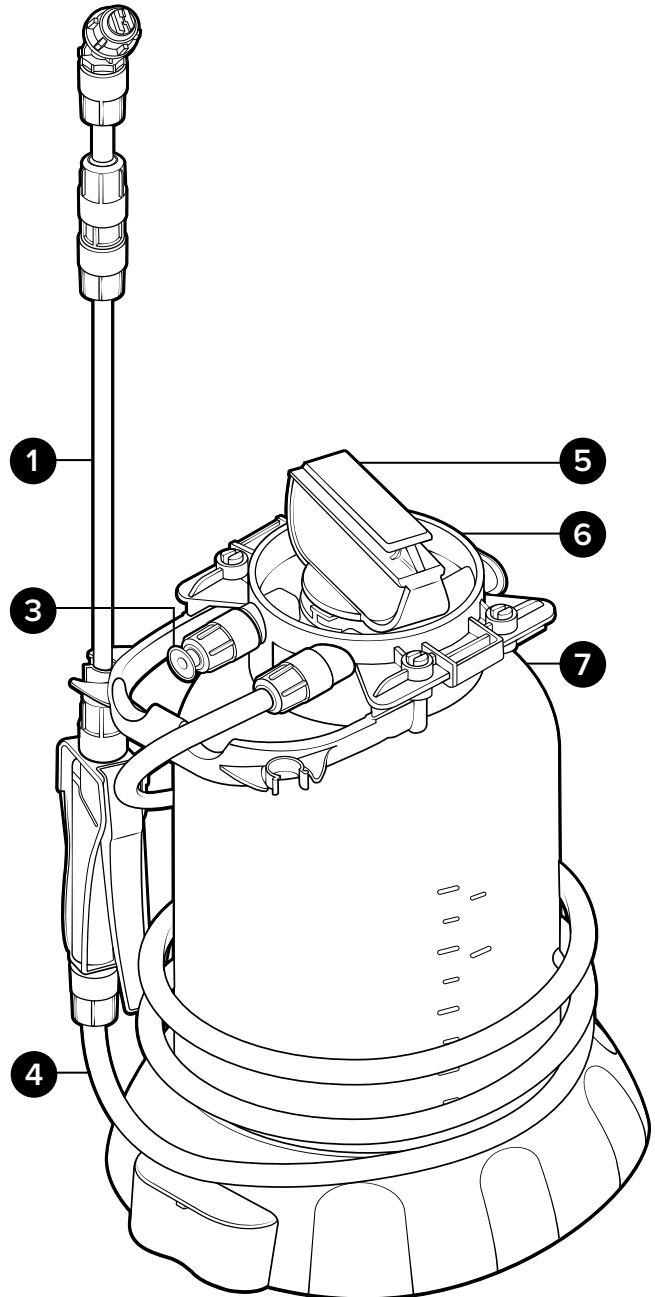

F5.0L

Using your unit

Maintenance Instructions

To keep your unit operating properly, periodically perform the following maintenance procedures.

Note: Before servicing your unit, release air pressure from the unit by activating the pressure relief valve.

- Check the pump assembly for wear and leaks.
- Check the suction line for debris and clean as needed.
- Periodically lubricate the pump seal with food safe lubricant. To lubricate the pump seal, raise the handle of the pump assembly and apply 5-10 drops of food safe lubricant between the pump and pump sleeve.
- If foam quality decreases, replace wadding with the following steps:

F5.0L:

1. Unthread the wand retaining nut (a) from the wand.
2. Remove old wadding (b), and insert new wadding.
3. Thread the wand retaining nut (a) back onto wand.

F5.0L-PSG:

4. Unthread the wand (c) from the trigger gun.
5. Remove old wadding (d), and insert new wadding.
6. Thread the wand (c) back onto the trigger gun.

Attachment Instructions

F5.0L-PSG attachments:

7. Remove wand (c) from the trigger gun, leaving the wadding (d) and o-ring (e) in the gun.
8. Install the attachment by threading it into the trigger gun. An additional o-ring will be supplied in the parts package of the attachment.

Drain tube attachment:

9. Remove wand retaining nut (f) and o-ring (g) from the lance. Set aside to use with the drain tube.
10. Remove spray tip (h), leave wadding (i) in the lance.
11. Insert press fit adapter (j) into retaining nut (f), then place the o-ring (g) behind the press fit adapter (j).
12. Thread the lance into the wand retaining nut (f), securing the o-ring (g) and press fit adapter (j) place.
13. Press the drain tube (k) into the press fit adapter (j).

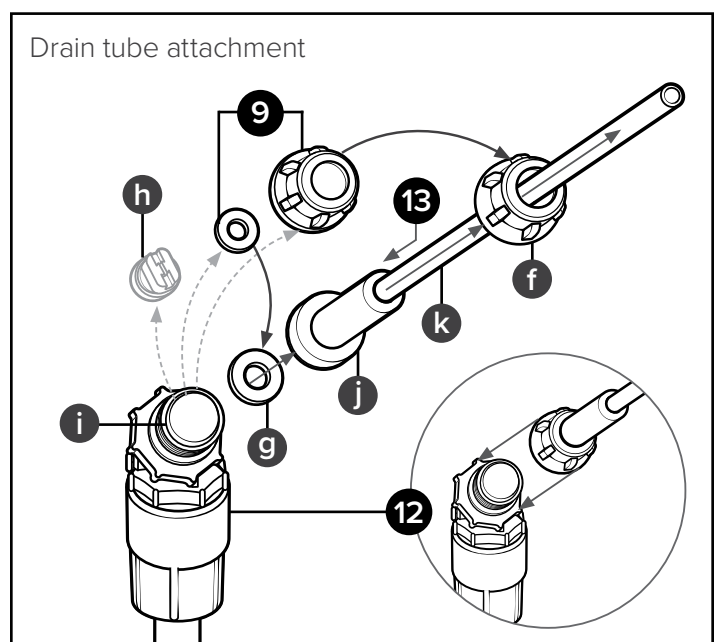
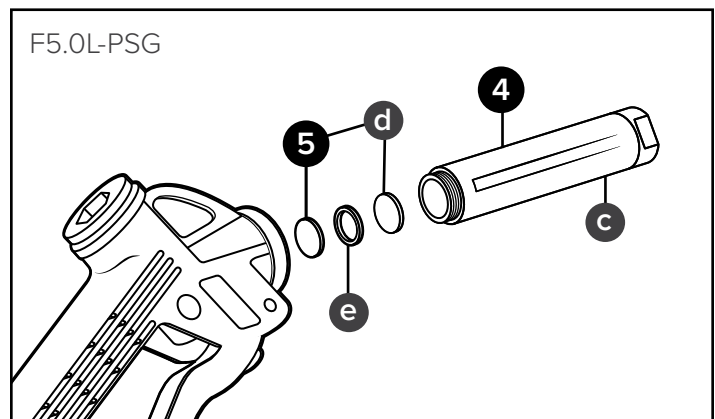
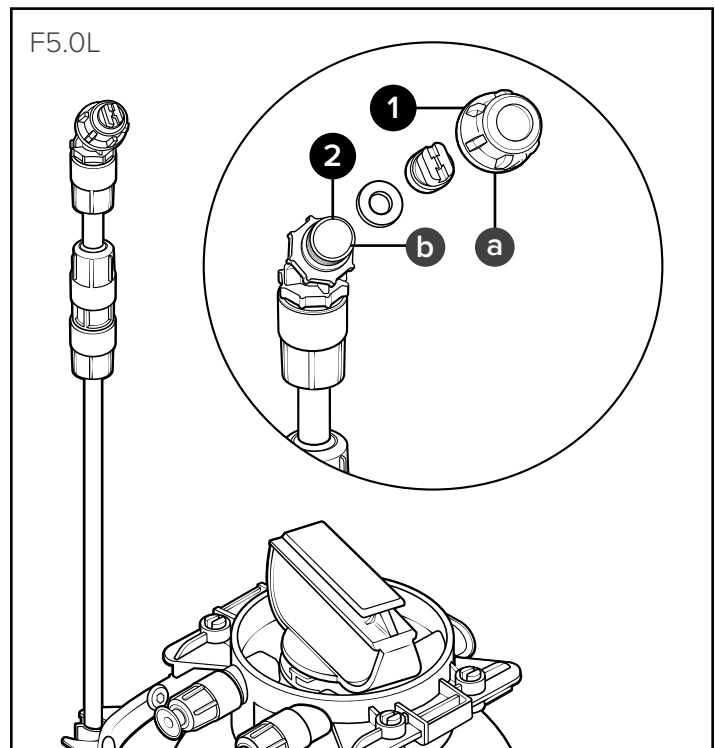

Servicing your unit

F5.0L

F5.0L:

5 liter pump-up foam unit

LC-SLA-F:

Short lance assembly - for 5L foam unit - includes spray tip, wadding, gasket, and retaining nut

Item number	Description
1 LC-SLA	Short lance (2 in.) assembly - no retaining nut, o-ring, wadding
2 LC-WD	Wadding disk for 5L/10L (1 piece)
3 LC-WA-OR	O-ring for 5L / 10L wand assembly
4 LC-STB	Button spray tip for 5L/10L
5 LC-WA-RN	Retaining nut for 5L / 10L wand assembly

Item number	Description
6 LC-LLA	Long lance (10 in.) assembly for 5L / 10L - with retaining nuts
7 LC-PRV	Pressure relief valve for 5L / 10L
8 LC-PSG	Poly spray gun for 5L / 10L - blue
9 LC-HA	Hose assembly for 5L / 10L
10 LC-PA	Manual pump assembly for 5L / 10L - Viton
11 LC-THA-F5.0L	Tank head assembly for 5L foam unit - with pressure relief valve and 5L poly supply tube
12 TANK5L	5 liter tank
13 LC-HNDL-CLP	Tank handle for 5L / 10L - with clips

LC-SLA-F

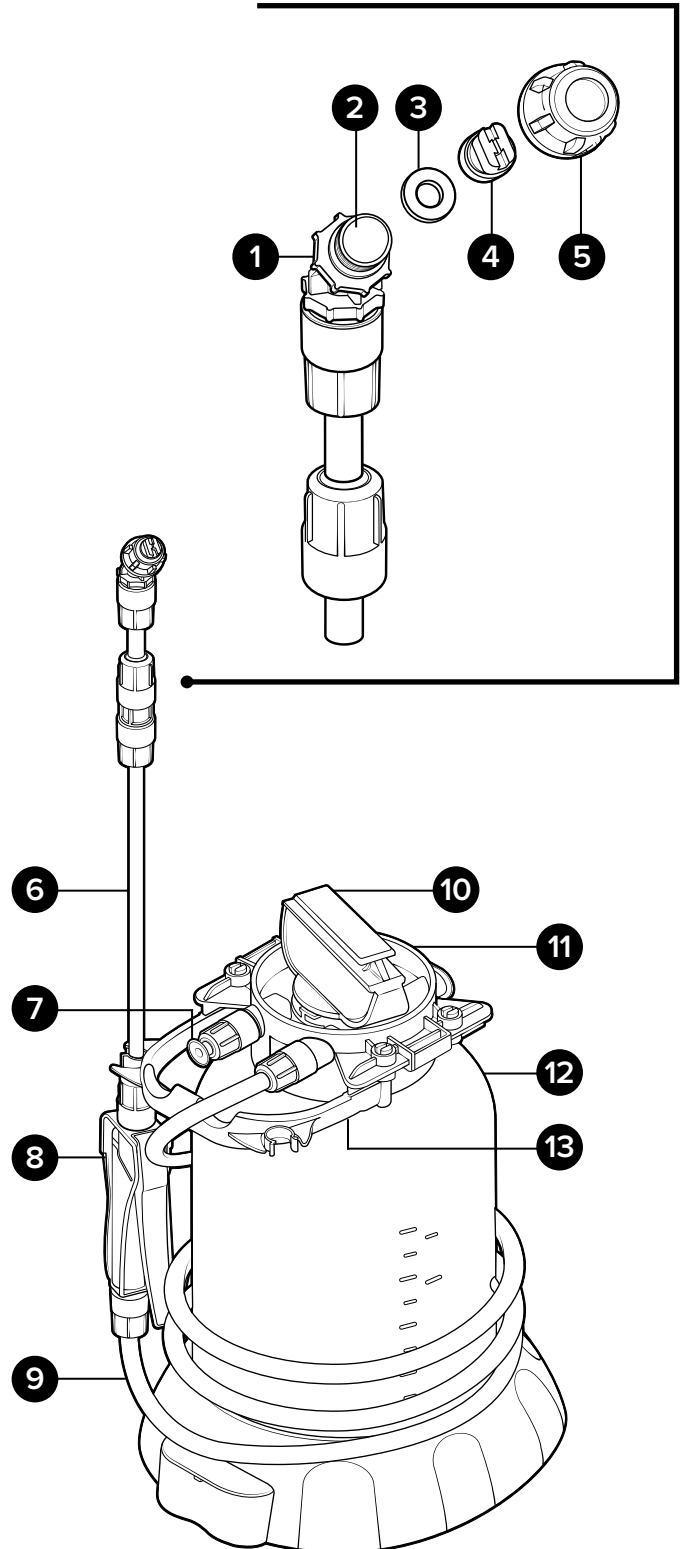

Servicing your unit

F5.0L-PSG

F5.0L-PSG:

5 liter pump up foam unit with PSG12 trigger gun

PSGA14PU-MX:

Poly spray gun assembly for ¼ in. hose - includes 4 in. black poly wand, spray tip, mixing media, hose barb, and screw band clamp

Item number	Description	
1	PUWAND	½ in. MPT poly wand with integrated 65 degree fan tip
2	MXPES-58	Mixing media - white polyester - wad - fine porosity - ⅝ in. dia x ⅞ in. tall
3	PSGORV	O-ring for poly spray gun
4	MXPES-12	Mixing media - white polyester - wad - fine porosity - ½ in. dia x ⅞ in. tall
5	PSG12	Poly spray gun with 2x ½ in. straight thread - gray handle with red clip - 316SS internal spring - includes 2x o-ring
6	HBSS1214	Hose barb - stainless steel - ½ in. MPT x ¼ in. barb
7	SSC14	Screw band clamp - stainless steel - for ¼ in. hose

Item number	Description	
8	LC-PRV	Pressure relief valve for 5L / 10L
9	LC-PA	Manual pump assembly for 5L / 10L - Viton
10	LC-THA-F5.0L	Tank head assembly for 5L foam unit - with pressure relief valve and 5L poly supply tube
11	TANK5L	5 liter tank
12	LC-HNDL-CLP	Tank handle for 5L / 10L - with clips

PSGA14PU-MX

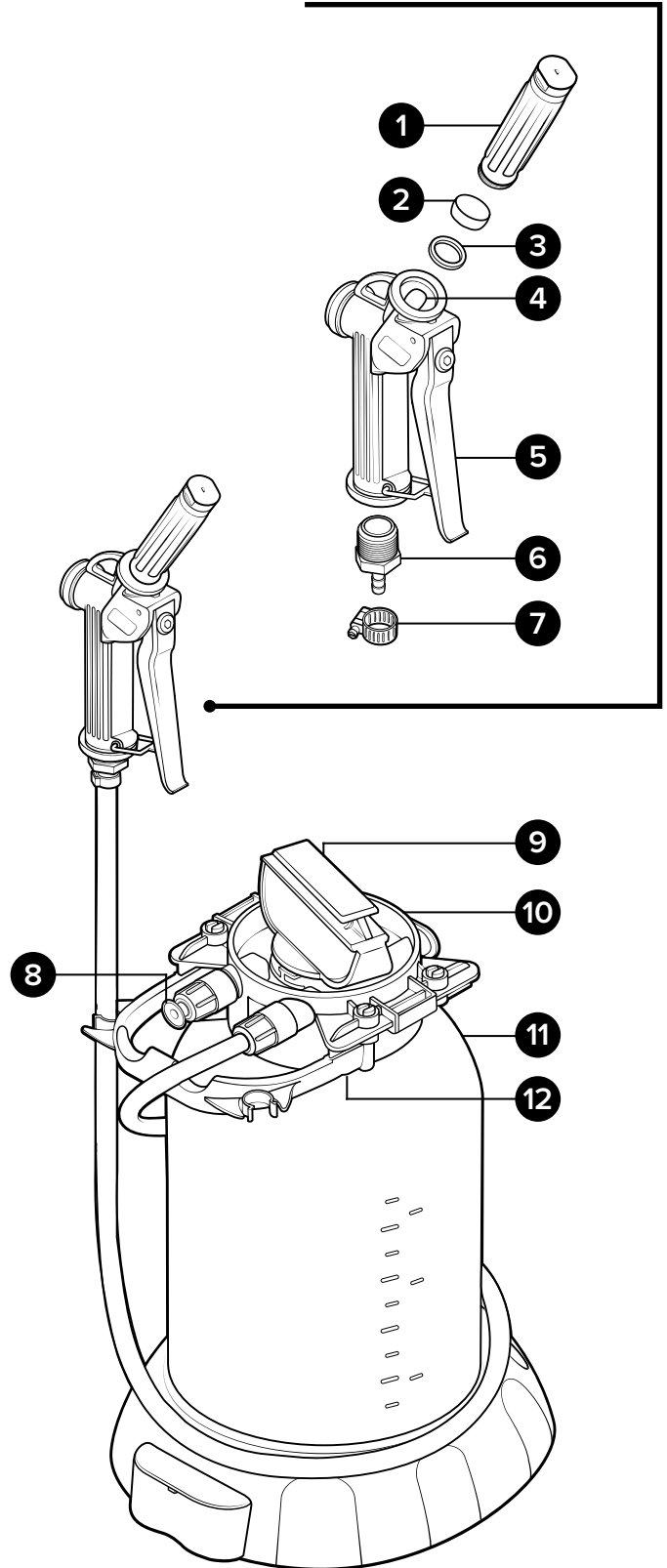

Attachment options

Not to scale

Hoof Attachment: DTA-18

Item number	Description
1	DT12-18 Drain discharge tube - ½ in. NPT and 8 mm od tube - black HDPE - 18 in. long
2	MXPES-34 Mixing media - white polyester - wad - fine porosity - ¾ in. diameter x 7/8 in. tall
3	PSGORV O-ring for PSG12 - Viton

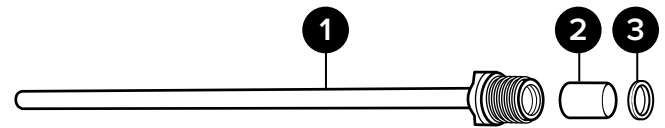

Drain Tube: LC-DT

Item number	Description
4	TB14N-PP-RGD-15 ¼ in. od natural tube - polypropylene - rigid - 15 in. long
5	ADPTR-PUTB14 Adapter - 1.5L pump-up wand to ¼ in. od tube - black polypropylene

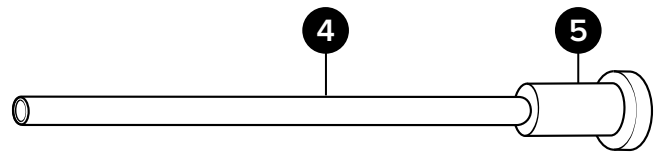

Teat Dip Cup: WA6-PP-DC-MX-EL

Item number	Description
6	DC12 Foam dip cup - ½ in. MPT - PP
7	PEL12F ½ in. female poly pipe elbow 90 degree
8	PN126 ½ in. NPT pipe nipple - black polypropylene - 6 in. long
9	MXPES-1 Mixing media - white polyester - wad - fine porosity - 1 in. diameter x 7/8 in. tall
10	PSGORV O-ring for PSG12 - Viton

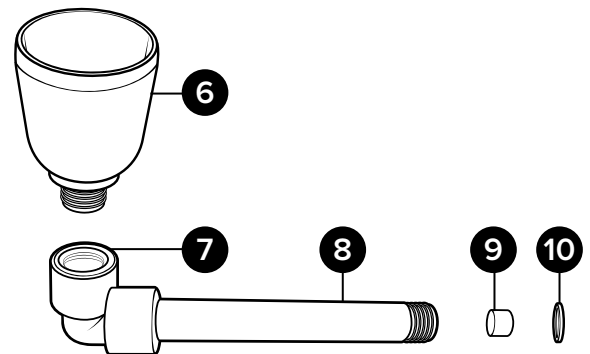

Drain Plunger Assembly: DFA-PLG5-18

Item number	Description
11	PN1218 ½ in. NPT pipe nipple - black polypropylene - 18 in. long
12	TB38N-PE ¾ in. od natural tube - polyethylene - available per ft.
13	SSC34 Screw band clamp - stainless steel - for ¾ in. hose
14	MXPES-34 Mixing media - white polyester - wad - fine porosity - ¾ in. dia x 7/8 in. tall
15	STRD1116 Strainer - stainless disc - 1 1/16 in. dia - #10 mesh
16	PLG12-5 Drain plunger - for ½ in. NPT pipe - black rubber - 5 ¼ in. dia

