USER MANUAL

MODEL NUMBER:

FG-10N-3

FG-10NK-3

FG-10NV-3

AND RELATED UNITS

**10 Gallon Air Operated Portable Fog
Equipment**

English (Original Instructions)

READ ALL INSTRUCTIONS BEFORE OPERATING EQUIPMENT

WARNING



Read this manual completely and understand the machine before operating or servicing it.

- Read all instructions before installing or operating unit.
- Always wear appropriate personal protective equipment (PPE) when operating or servicing unit.
- Always follow all chemical safety precautions and handling instructions provided by the chemical manufacturer and Safety Data Sheet (SDS).
- If this unit is modified or serviced with parts not listed in this manual, the unit may not operate correctly.
- Always depressurize unit after use (as described in the After Use Instructions).
- Do not exceed an incoming air pressure of 100 psi (7 bar).
- Do not exceed a fluid temperature of 100°F (37°C).
- Always flush the unit with fresh water for 5 minutes when switching from an alkaline to an acid or an acid to an alkaline.
- Never use unit with hydrocarbons or flammable products.
- Only use clean and dry air. Air must be filtered and free of moisture or pump life will be diminished. If needed, install an air dryer before unit.
- Do not use an air lubricator before the unit.
- Never use unit if it is damaged or leaking.

PROTECT THE ENVIRONMENT

Please dispose of packaging materials, old machine components, and hazardous fluids in an environmentally safe way according to local waste disposal regulations.



Always remember to recycle.

Specifications and parts are subject to change without notice.

READ ALL INSTRUCTIONS BEFORE OPERATING EQUIPMENT

OPTIONS		
	Pump Seal Material	
FG-10N	Santoprene (<i>standard</i>)	-3
	Viton (V)	
	Kalrez (K)	
Add bold option codes to item number as shown. For standard options, no option code is needed. Examples: <ul style="list-style-type: none"> • FG-10N-3 (standard unit with Santoprene pump seals) • FG-10NV-3 (unit with Viton pump seals) 		

REQUIREMENTS	
Compressed air requirements	50 psi (3.4 bar) with 9 cfm (254.9 l/min)
Liquid temperature range	40-100°F (4.4-37°C)
Chemical compatibility	Chemical products used with this equipment must be formulated for this type of application and compatible with unit materials and pump seals. For more information on chemical compatibility, consult the manufacturer or SDS for your product or contact our customer service department.

SPECIFICATIONS	
Power type	Compressed air
Chemical pickup type	Draws from pre-mixed solution
Number of products unit can draw from	One product
Suction line length/diameter	3/8 in. (9.5 mm) inside diameter
Capacity	12.5 gallons (47.32 liters)
Flow rate*	3.7 gal/hour at each nozzle
Pump seals	Santoprene, Viton, or Kalrez
Droplet size	15 microns at 50 psi
Coverage area**	1 liter of solution will cover approximately 1000 cubic feet (up to system max of 47,320 cubic feet).
Run time from full tank**	Approx. 1 hour
Number of nozzles	3 nozzles
Fog mast height range	3.5-8.5 ft. (1.1-2.6 m)
Wheel type	Two 10 inch non-marking wheels

*Dilution rates and flow rates given are based on chemical with viscosity of water and factory air pressure settings.

**Area covered and run time may vary based on humidity, air flow, and product used.

READ ALL INSTRUCTIONS BEFORE OPERATING EQUIPMENT

Assembly Instructions

1. Remove all components from packaging.
2. Attach the fog nozzle assembly to the top of the fog mast using the screw provided in the parts package. The fog nozzles (PFN-N130) should point upwards.
3. Push one end of the red tube into the fitting labeled “RED” on the unit’s back plate.
4. Push one end of the blue tube into the fitting labeled “BLUE” on the unit’s back plate.
5. Connect the other ends of the red and blue tubes to the fog nozzle assembly. Locate the two tee fittings (QFT38) with an open port and connect the solution line (red) to the liquid tee and the air line (blue) to the air tee. To determine which tee is air and which is liquid, trace the clear tubing from the tee to one of the fog nozzles (PFN-130) – on the body of the nozzle, the air line is labeled “AIR” and the liquid line is labeled “LIQ.”
Note: Make sure to insert the tubing all the way into the fittings to ensure proper connection.

Operation Instructions

Always follow all chemical safety precautions and handling instructions provided by the chemical manufacturer and Safety Data Sheet (SDS).

1. Follow all instructions from chemical manufacturer. Fill the tank with water and the advised percentage of chemical concentrate.
2. Place the unit in the area to be fogged.
3. Adjust the fog mast to the desired height. To change the height, loosen the collar screws, move the mast up or down as needed, then retighten the collar screws to secure the mast.
Caution: To prevent injury from collapsing mast, always support the mast when adjusting height. Always make sure the collar screws are tight and secure before letting go of the mast.
4. Ensure the air supply valve (BVB14) is in the closed position, and connect a compressed air line to the air inlet fitting (AP25).
5. Open the air supply valve (BVB14) to activate the unit.
6. Evacuate the area.
7. After the unit has stopped fogging, observe all appropriate safety precautions before reentering area. Close the air supply valve (BVB14) and disconnect the compressed air line from the unit.
8. Before moving the unit, always lower the fog mast completely and secure it in the lowest position.

After Use Instructions:

1. Flush the unit with fresh water for 5 minutes.
2. Disconnect the air line from the air fitting (AP25).

Maintenance Instructions:

To keep your portable unit operating properly, periodically perform the following maintenance procedures:

- Check the air pump (P56/P56K/P56V) for wear and leaks.
- Inspect hoses for leaks or excessive wear. Make sure all hose clamps are in good condition and properly secured.
- Check the suction tube and screen for debris and clean as needed.
- Drain compressor tank on a regular basis to ensure proper operation of pump.

Troubleshooting Instructions:

- If air passes through the pump (P56/P56K/P56V) without cycling, the pump needs to be replaced.
- Check the chemical suction line and strainer for debris or damage. Clean or replace as needed. To prevent damage to the unit, the strainer (STR38-IL) must always be used.
- Check for proper air pressure on air gauge (AG100). Air regulator (R14) is factory set at 50 psi (3.4 bar).
- If the unit foams at a reduced pressure:
 - o Check the air compressor supplying the unit. If the pressure is less than 40 psi, turn the foam unit off until the compressor can catch up.
 - o If the air supply is 50 psi (3.4 bar) or above, check the AG100, which should read near 50 psi (3.4 bar). If the AG100 is more or less than 50 psi (3.4 bar), adjust the pressure by turning the knob on the top of the air regulator (R14).

READ ALL INSTRUCTIONS BEFORE OPERATING EQUIPMENT

Tank Assembly

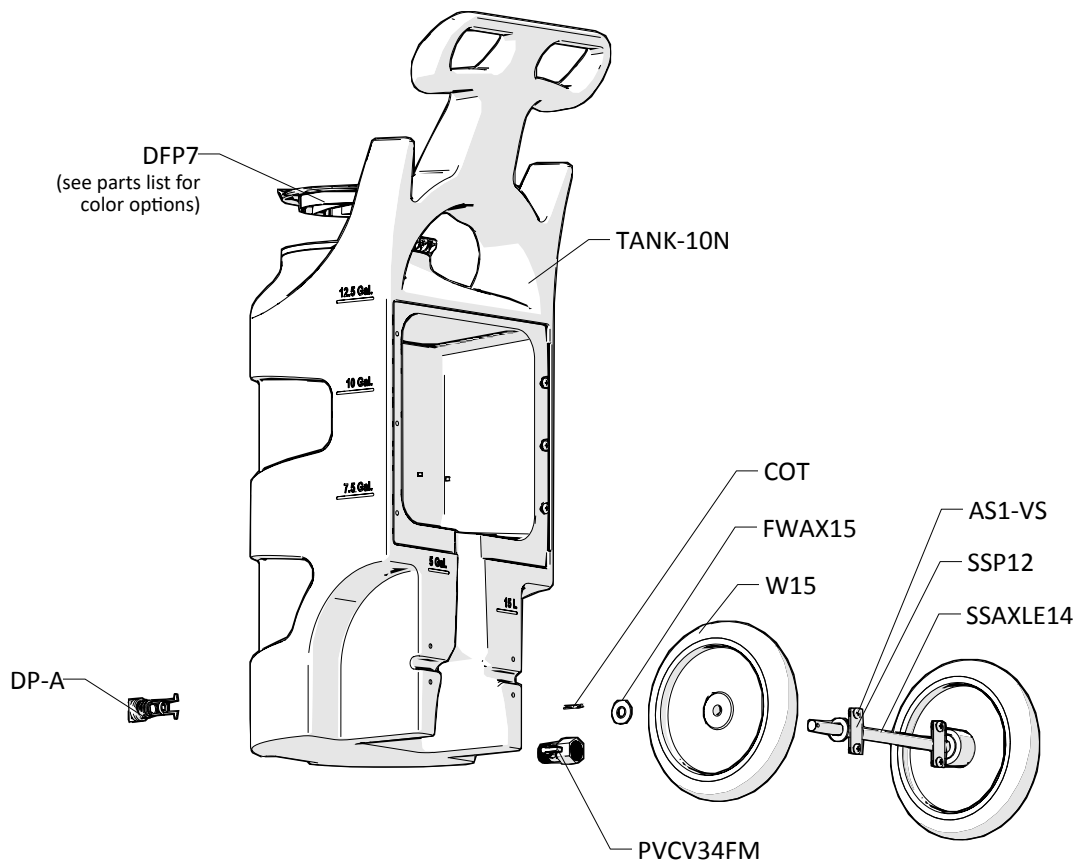

OPTIONAL COMPONENTS

AIR HOSE ASSEMBLY
ITEM NUMBER: AH30

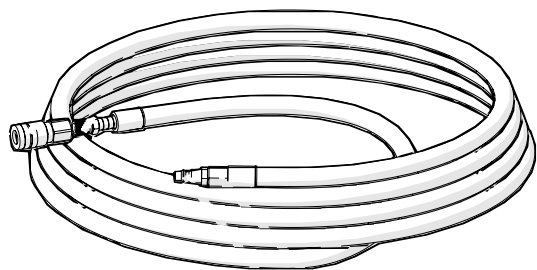

WATER SEPARATOR
ITEM NUMBER: WS-20CFM

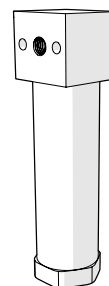

READ ALL INSTRUCTIONS BEFORE OPERATING EQUIPMENT

Plate - Inside View

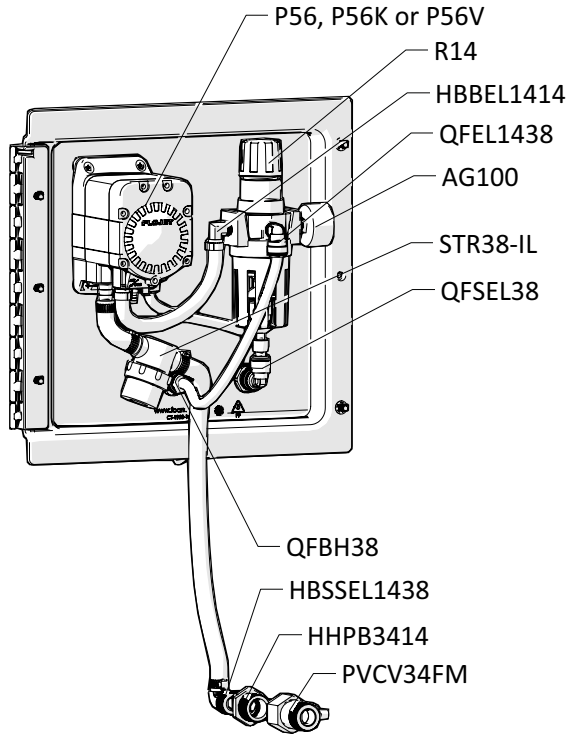
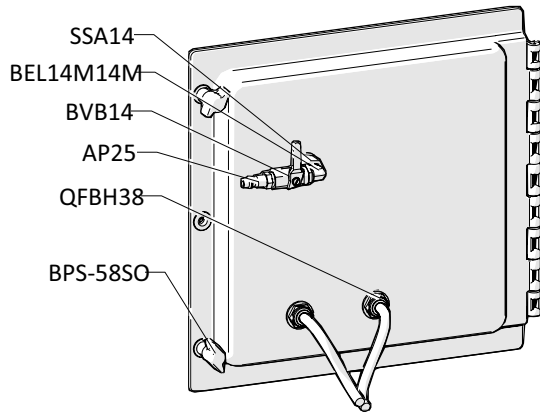
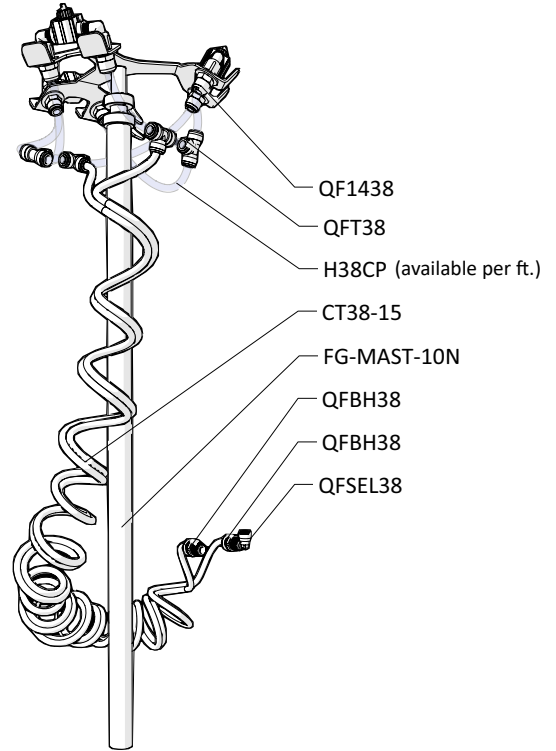

Plate - Back View



Fog Mast Assembly

ITEM NUMBER: 3NA-N130-MAST



Fog Mast - Top View

ITEM NUMBER: 3NA-N130

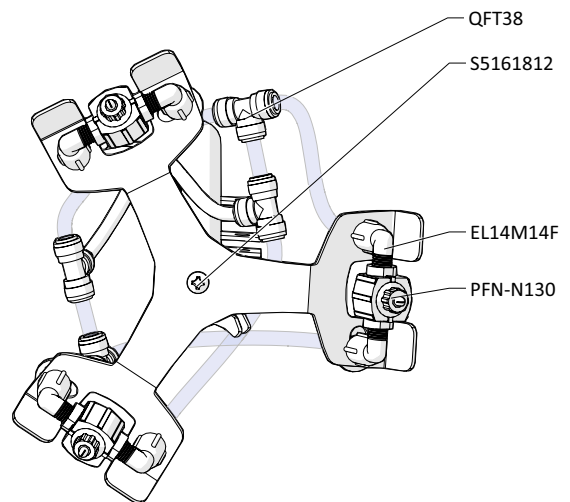

READ ALL INSTRUCTIONS BEFORE OPERATING EQUIPMENT

ITEM NUMBER	DESCRIPTION
3NA-N130	FG-10N-3 TOP BRACKET ASSEMBLY WITH 3 PFN-N130 NOZZLES
3NA-N130-MAST	FG-10N-3 COMPLETE MAST ASSEMBLY
AG100	1.5 INCH DRY MODEL 20 DUAL SCALE GAUGE
AH30	30 FT. AIR HOSE WITH QUICK CONNECT FITTINGS
AP25	PLUG 1/4 NPTM AIR FITTING - BRASS
AS1-VS	1/4-20 X 1/2 PHIL TRUSS MACH SCREW 19-8 W/516 ORANGE VIBRASEAL PATCH
B103234	10-32 X 3/4 PHIL TRUSS MACH SCR 18-8
B8X58	8-15 X 5/8 inch PHIL FLAT TY-A 316 S.S.
BEL14M14M	BRASS ELBOW 1/4in MPT X 1/4in MPT
BPS-58SO	Back Panel Screw - 5/8 inch with Stand Off
BPS-SSR	1/4 INCH PUSHNUT BOLT RETAINER STAINLESS STEEL
BVB14	AIR INLET VALVE - VA BRS 025-4F4F-BT, NICKEL
COT	1/8 X 1 COTTER PIN 18-8 S/S
CT38-15	3/8 INCH X 15 FT COILED BLACK AND CLEAR TUBING-POLY URETHANE
DFP7	7 INCH HINGED CAP ASSEMBLY - INCLUDES BLACK CAP, LID FLANGE AND HINGE PIN
<i>DFP7-C</i>	7 INCH FILL CAP POLYPRO BLACK
<i>DFP7-F</i>	7 INCH TANK LID FLANGE POLYPRO
<i>DFP7-PIN</i>	HINGE PIN FOR DFP7-C & DFP7-C
DFP7-C-BL	7 INCH FILL CAP POLYPRO BLUE PANTONE
DFP7-C-GN	7 INCH FILL CAP POLYPRO GREEN PANTONE
DFP7-C-RD	7 INCH FILL CAP POLYPRO RED PANTONE
DFP7-C-YL	7 INCH FILL CAP POLYPRO YELLOW PANTONE
DP-A	DRAIN PLUG ASSEMBLY FOR TANK-10N TANK-20N
<i>DP</i>	FRONT DRAIN PLUG FOR PORTABLE UNIT POLYPRO
<i>DP-G</i>	FKM SQUARE CUT DRAIN PLUG GASKET
EC14-2	OETIKER CLAMP 13.8
EL14M14F	1/4 FEM PIPE X 1/4 M PIPE ELBOW
FG-MAST-10N	FOG MAST FOR TANK-10N-IN
FWAX15	FLAT AXLE WASHER
FWLG14	.569 ID X 1.28 OD X .08 THICK FLAT WASHER SS 18-8
H14B-F	1/4 INCH BLUE HOSE-HYBRID TPE-Available per ft.
H38B-F	3/8 INCH BLUE HOSE-HYBRID TPE-Available per ft.
H38CP	3/8IN OD POLYETHYLENE TUBING - NATURAL
HBBEL1414	1/4 MPT X 1/4 HOSE BARB BRASS 90 DEG
HBSEL1438	STAINLESS HOSE BARB ELBOW 1/4 INCH NPT X 3/8 HOSE BARB
HHBB1418	HEX HEAD BRASS BUSHING 1/4in X 1/8in

HHPB3414	HEX HEAD POLY REDUCER BUSHING 3/4 X 1/4
P56	5700 PUMP WITH SANTOPRENE SEALS - INCLUDES HOSE BARBS, AIR FITTING, AND AIR PORT
P56K	5700 PUMP WITH KALREZ SEALS - INCLUDES HOSE BARBS, AIR FITTING, AND AIR PORT
P56V	5700 PUMP WITH VITON SEALS - INCLUDES HOSE BARBS, AIR FITTING, AND AIR PORT
<i>20756103B</i>	Polypro G57 Air Port x HB Straight, w/ Viton o-ring
<i>HB14P</i>	1/4in BRASS HB AIR FITTING /G57/P56
<i>HB5638</i>	HOSE BARB FOR P56 PUMP
<i>HB5638K</i>	HOSE BARB FOR P56K PUMP
<i>HB5638V</i>	HOSE BARB FOR P56V PUMP
<i>QF5638</i>	3/8in QF PUMP FITTING / G57
PFN-N130	PNEUMATIC FOG NOZZLE - POLYPROPYLENE AND KYNAR TIP - 3.7 GAL/HR PER NOZZLE
PLPF-B	BLANK PORTABLE FOAMER PLATE WITH HINGE W/O HOLES
PLPF-PIN	302 STAINLESS PORTABLE PLATE HINGE PIN
PVCV34FM	PVC VALVE 3/4in FPT X 3/4in MPT
QF1438	MALE CON. 3/8in TUBE X 1/4in MPT - POLYPROPYLENE
QF5638	3/8in QF PUMP FITTING / G57
QFBH38	BULKHEAD 3/8in TUBE POLYPROPYLENE
QFEL1438	FIXED ELBOW 3/8in TUBE X 1/4in MPT - POLYPROPYLENE
QFSEL38	PLUG-IN ELBOW 3/8in TUBE X 3/8in POLYPROPYLENE
QFT38	UNION TEE 3/8in TUBE POLYPROPYLENE
R14	1/4 NPTF REGULATOR W/ FILTER-NO GAUGE
S142058-VS	1/4-20 X 5/8 PHIL TRUSS MACHINE SCREW 18-8 W/#516 VIBRASEAL ORANGE PATCH
S5161812	5/16-18 x 1/2 Phil Pan 18-8
SSA14	SS304 MALE/FEMALE ADAPTOR 1/4 NPT X 1/4 NPT
SSAXLE14	14 1/2" long with the 5/8" diameter bar & 2 through holes with countersinks beveled ends
SSC38	WORM GEAR CLAMP, S/S (.25-.63)
SSP12	STAINLESS STEEL AXLE PLATE - 2.5 inch X 1 inch - 2 HOLE
STR38-IL	IN LINE STRAINER 3/8 BARB 20 MESH 304 STAINLESS EDPM GSKT
TANK-10N-IN	NATURAL 10 GALLON TANK WITH SIDE INSERTS
TW916	1/2 INT TOOTH L/W 410SS
W15	NONMARKING WHEEL FOR PORTABLE UNITS
WS-20CFM	TSUNAMI WATER SEPARATOR 20 CFM

TIMER ADJUSTMENT INSTRUCTIONS

The TR120MF is a multifunction timer.

1. The four switches in the top left (Function) control the timer mode. For fogging/misting applications, switches **A**, **C**, and **D** should be ON, and switch **B** should be OFF. This puts the timer in Dual Mode.
2. The six switches in the bottom left (Time Base) control the time interval. The timer is factory set to MINUTES. To change the Time Base to seconds or hours, refer to the chart below.
3. The five switches in the top right (Dual Mode t1) control the delay time.
4. The five switches in the the bottom right (Dual Mode t2) control the run time. The active time for each function is equal to the combined values of any switch(es) that are ON.

NOTICE: the timer is factory set at 2 minute delay, 8 minute run time.

1. FUNCTION (A to D):
This setting puts the time in Dual Mode.

2. TIME BASE (E to K):
Switches E, F, and G control t1.
Switches H, J, and K control t2.

SEE CHART ON SIDE FOR FUNCTION & TIME BASE SETUP

Timer Setting Example

In this example, the delay time has been set to 5 minutes, and the run time has been set to 20 minutes.

1. The FUNCTION is set to Dual Mode.
2. The TIME BASE is set to minutes.
3. The total DELAY time is 5 (1+4=5)
4. The total RUN time is 20 (4+16=20)

SELECT FUNCTION				
FUNCTION	A	B	C	D
ON DELAY	OFF	OFF	OFF	OFF
INTERVAL ON	ON	OFF	OFF	OFF
OFF DELAY	OFF	ON	OFF	OFF
TR. ON DELAY	ON	ON	OFF	OFF
FLASHER (ON)	OFF	OFF	ON	OFF
FLASHER (OFF)	ON	OFF	ON	OFF
WATCHDOG	OFF	ON	ON	OFF
ONE SHOT F. EDGE	ON	ON	ON	OFF
SINGLE SHOT	OFF	OFF	OFF	ON
CYCLE (ON)	ON	OFF	OFF	ON
CYCLE (OFF)	OFF	ON	OFF	ON
DELAYED INTERVAL	ON	ON	OFF	ON
ON/OFF DELAY	OFF	OFF	ON	ON
TR. DELAYED INT.	ON	OFF	ON	ON
ONE SHOT-FLASHER	OFF	ON	ON	ON
ON DELAY/FLASHER	ON	ON	ON	ON

NOTE: SWITCHES H,J,&K ARE ONLY USED ON DUAL MODE FUNCTIONS