

Wall Mounted Pneumatic Teat Foam System and Applicator

User Manual

FI-WL-LVTL-CB

PSGATL4-DC-MX-CTB14-12-CV-DA

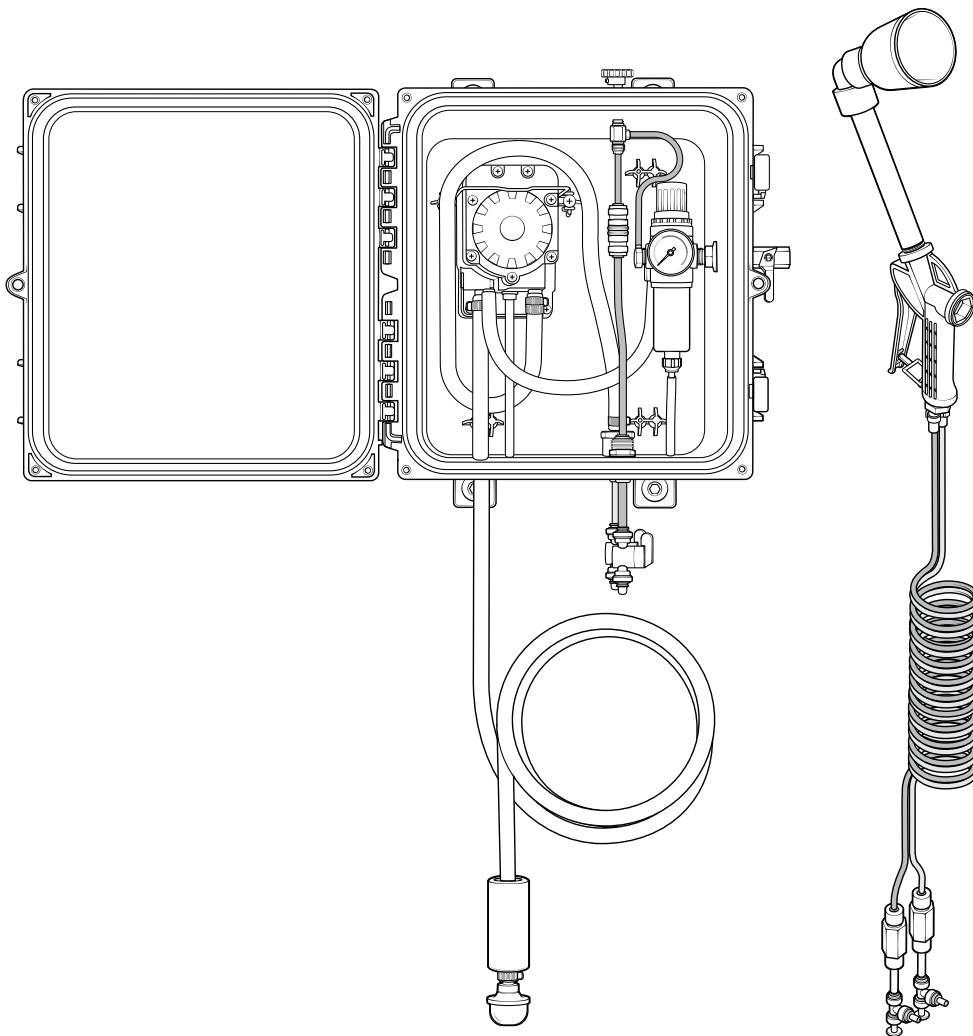

READ ALL INSTRUCTIONS BEFORE USING OR
SERVICING THIS UNIT. KEEP THIS MANUAL IN A
LOCATION THAT IS READILY AVAILABLE TO USERS
AND SERVICE TECHNICIANS.

English (Original Instructions)



Scan this code
for user manual



Safety

WARNING

PEOPLE OR OBJECTS CAN BE HURT OR DAMAGED IF THIS UNIT IS NOT USED CORRECTLY!



Failure to read all the instructions before operating the unit may result in personal injury or death from the improper use or the chemical solution. Anyone handling, operating or using the unit must read, and understand, the instructions in the manual. The buyer assumes all responsibility for safety and proper use in accordance with the instructions.



Using, or servicing, the unit without proper protective clothing, gloves, and eye wear may result in serious injury such as burns, rashes, eye, throat or lung damage and death. Always wear protective clothing, gloves, and eye wear when using, or servicing, the unit. Protect eyes, skin, and lungs against drifting spray.



Chemical solutions may pose a health risk and death if they contact the skin or eyes, are inhaled or swallowed. Always read, and follow, all chemical safety precautions and handling instructions provided by the chemical manufacturer and the Safety Data Sheet (SDS) associated with the chemical solution being used before using the unit.



Pressure within the equipment may cause an unexpected release of the chemical solution and cause serious injury such as burns, rashes, eye damage, throat or lung damage and death. Always depressurize and clean the unit after each use. Release any remaining air pressure by twisting the pressure relief valve to the right ½ turn. Never leave the unit unattended while pressurized.

Using the unit with fluid temperatures above 100°F (37.8°C) may result in scalding, burns, serious injury or death. DO NOT use a solution with a temperature above 100°F (37.8°C).

Operating the unit when damaged or leaking may result in exposure to chemical solutions, serious injury or death. Never use the unit if it is damaged or leaking.



Using incoming air pressure exceeding 100 psi (6.9 bar) may result in pressure buildup, explosion, serious injury or death. DO NOT exceed 100 psi (6.9 bar) incoming air pressure when operating unit.

Use of hydrocarbons and flammable products may result in explosions, fire and serious injury or death. Never use hydrocarbons or flammable products with the unit.



Performing any maintenance with the unit turned ON, plugged into an electrical power source or connected to the air and water supply may cause serious injury or death. Always ensure that the unit has been turned OFF, unplugged from the electrical power source, and disconnected from the air/water supply before conducting any maintenance.



Mixing an alkaline with an acid may result in a chemical reaction. Overheating of the mixture may cause it to splatter caustic compounds or release hazardous fumes, gas and vapors. Always flush the unit with fresh water thoroughly when switching from an alkaline to an acid or an acid to an alkaline.

NOTICE

Servicing, or modification, of this unit with parts not listed in this manual may cause the unit to operate improperly. Do not use unauthorized parts when servicing the unit.

Use of an air lubricator before the unit may result in diminished performance and damage to the unit. Do not use an air lubricator before the unit.

Moisture in the air lines will damage the pump and diminish the pumps life. The air must be filtered, clean, dry and free of moisture. If needed, install an air dryer before the unit.

PROTECT THE ENVIRONMENT



Please dispose of packaging materials, old machine components, and hazardous fluids in an environmentally safe way according to local waste disposal regulations

Product Overview

Requirements

Compressed air requirements	40–80 psi (2.8-5.5 bar) with 5–10 CFM (141.6-283.2 l/min)
Liquid temperature range	40-100°F (4.4–37.8°C)
Chemical compatibility	Chemical products used with this equipment must be formulated for this type of application and compatible with unit materials and pump seals. For more information on chemical compatibility, consult the manufacturer or SDS for your product or contact our customer service department.

Specifications

Power type	Compressed air
Chemical pickup type	Draws from pre-mixed solution
Number of products unit can draw from	One product
Suction line length/diameter	8 ft. (2.4 m) hose with $\frac{3}{8}$ in. (9.5 mm) inside diameter
Discharge line length/diameter	12 ft. (3.7 m) or 25 ft. (7.6 m) of twin-line tubing, with $\frac{1}{4}$ in. (6.35 mm) outside diameter (coiled and bonded)
Discharge wand/tip type	Polypropylene trigger handle with dip cup (sold separately)
Output volume	3.5 gal/min (13.2 l/min)
Flow rate*	0.5 gal/min (1.9 l/min)
Pump seals	Santoprene, Viton, or Kalrez
Product height	15 in. (38.1 cm)
Tubing/fitting sizes	Designed for use with $\frac{1}{4}$ in. (6.4 mm) outside diameter tubing between control box and drop station assemblies

*Dilution rates and flow rates given are based on chemical with viscosity of water and factory air pressure settings.

Product Components

Before you begin get to know the components that you will need to use, adjust or assemble.

FI-WL-LVTL-CB:

Control box

PSGATL4-DC-MX-CTB14-12-CV-DA:

Drop station

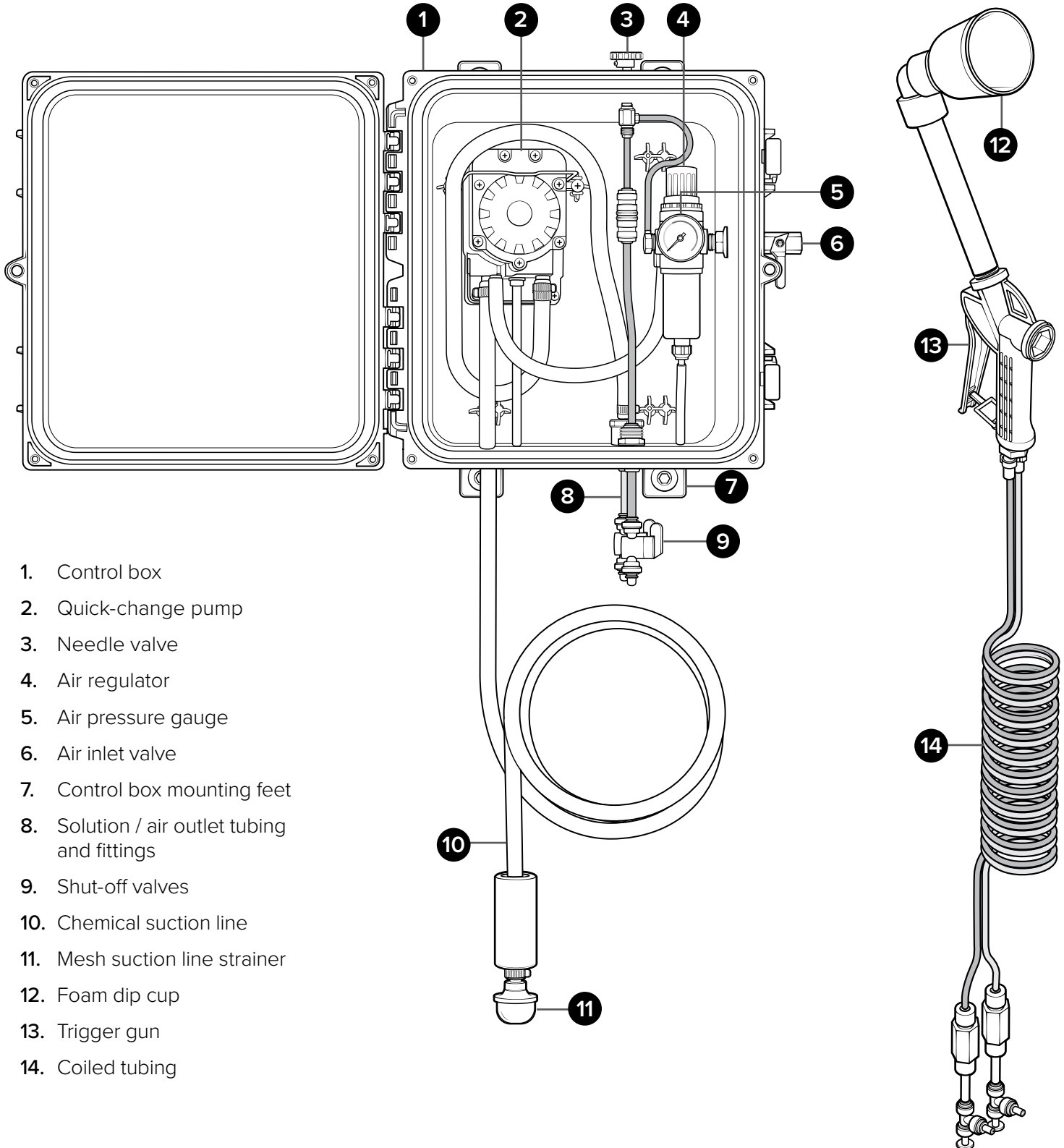

1. Control box
2. Quick-change pump
3. Needle valve
4. Air regulator
5. Air pressure gauge
6. Air inlet valve
7. Control box mounting feet
8. Solution / air outlet tubing and fittings
9. Shut-off valves
10. Chemical suction line
11. Mesh suction line strainer
12. Foam dip cup
13. Trigger gun
14. Coiled tubing

Assembly

1. Remove all components from packaging.
2. Select desired area to mount the control box.

Note: We recommend mounting the control box at a height of 8 feet or less. Chemical suction line must reach bottom of the chemical container. The bottom of the chemical container should not be positioned higher than the bottom of control box.

3. Attach the control box mounting feet to the back of the control box, using the 4 screws provided in the parts package.
4. Mount the control box to the wall using four of the screws and plastic anchors provided in the parts package.

Note: To drill holes for the plastic anchors, use a 5/16 in. drill bit.

Drop stations, dip cups, and tubing are sold separately from the control box. The number of drop stations and amount of tubing required depends on the facility. Contact your chemical or equipment rep for assistance.

5. Run one ¼ in. OD tube from liquid discharge and another from air discharge out to the drop stations.
6. Install ¼ in. shut-off valves on the end of the air and liquid lines.

Note: When installing more than one drop, it is recommended to have both liquid (red) and air (blue) lines loop back to a tee placed in-line below the control box to avoid dead ends in either supply line. This will help to equalize line pressure to all drops.

7. Connect tubing and foam guns to the shut-off valve, then make sure the valves are in the open position.

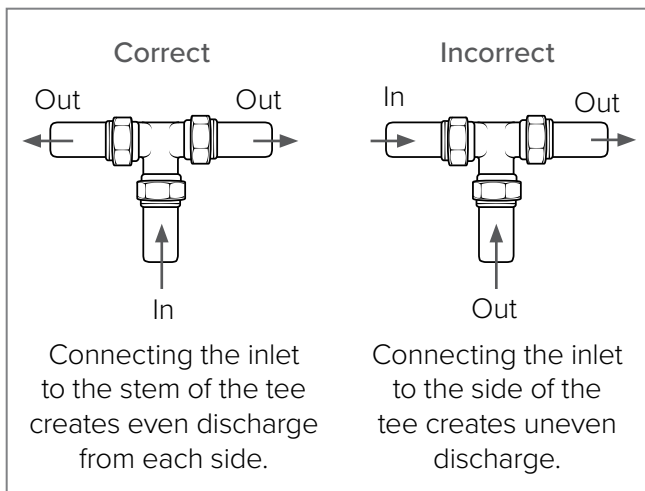
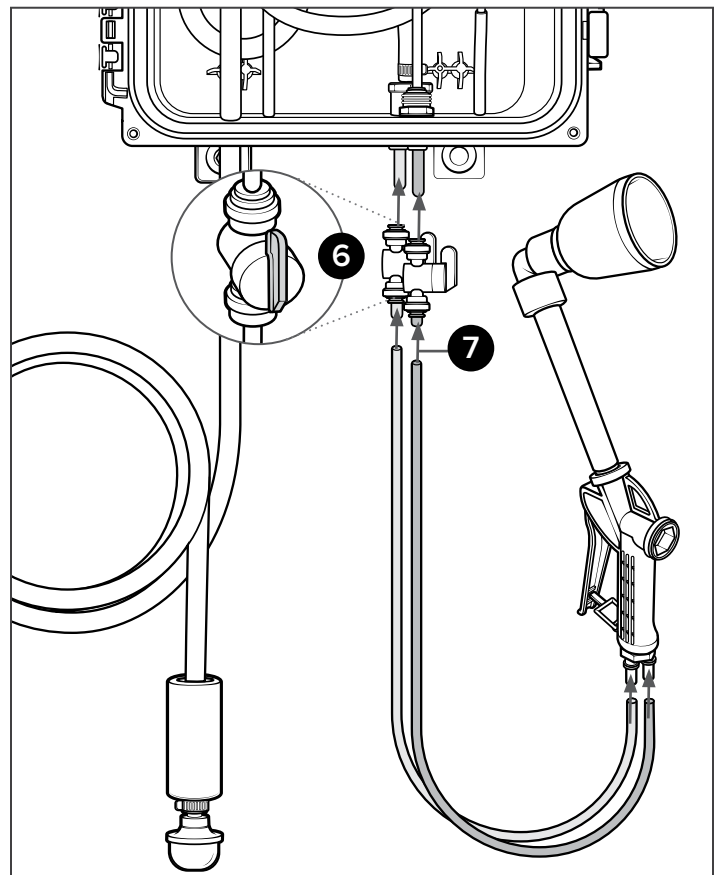
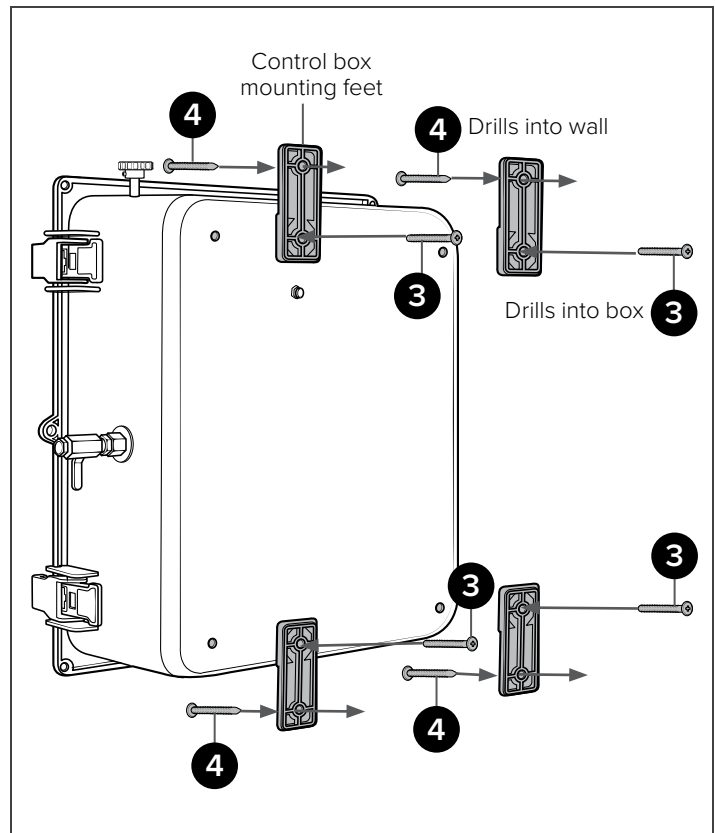

Using your unit

Operating Instructions

1. Follow all instructions from chemical manufacturer.
2. Place the chemical suction line into a container of pre-mixed chemical solution.
3. With the discharge trigger handle in the closed position, open the air inlet valve.
4. Point the discharge wand in a safe direction and squeeze the trigger handle to begin foaming. Release the trigger handle to stop foaming.
5. While the unit is running and discharging product, adjust the needle valve located on top of the control box as needed to regulate the wetness or dryness of the foam following the steps below:
 - a. Close needle valve completely in clockwise direction.
 - b. Open needle valve in counterclockwise direction 2 complete turns.
 - c. Continue to open needle valve in $\frac{1}{4}$ turn increments, allowing 30 seconds between adjustments, until desired consistency of foam is achieved.

After Use Instructions

We recommend flushing the discharge hose and depressurizing the unit after each use.

6. Place the chemical suction line into a container of water.
7. With the unit running, squeeze the discharge trigger handle and allow unit to be flushed with fresh water thoroughly until all chemical has been discharged from the system.
8. Shut off the air supply to the unit by closing the air inlet valve.
9. Squeeze discharge trigger handle to relieve any pressure remaining in the unit.
10. Release the trigger handle after all pressure has been relieved from the unit. Store the unit with the trigger handle in the closed position.

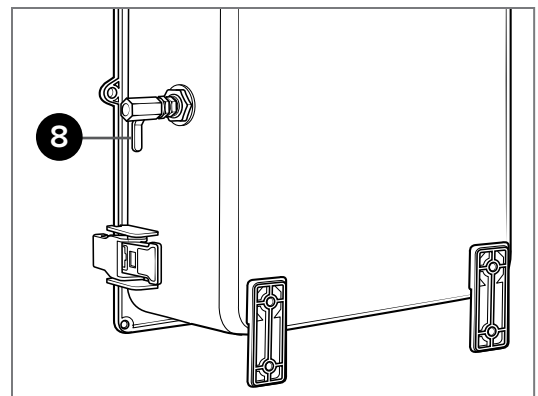
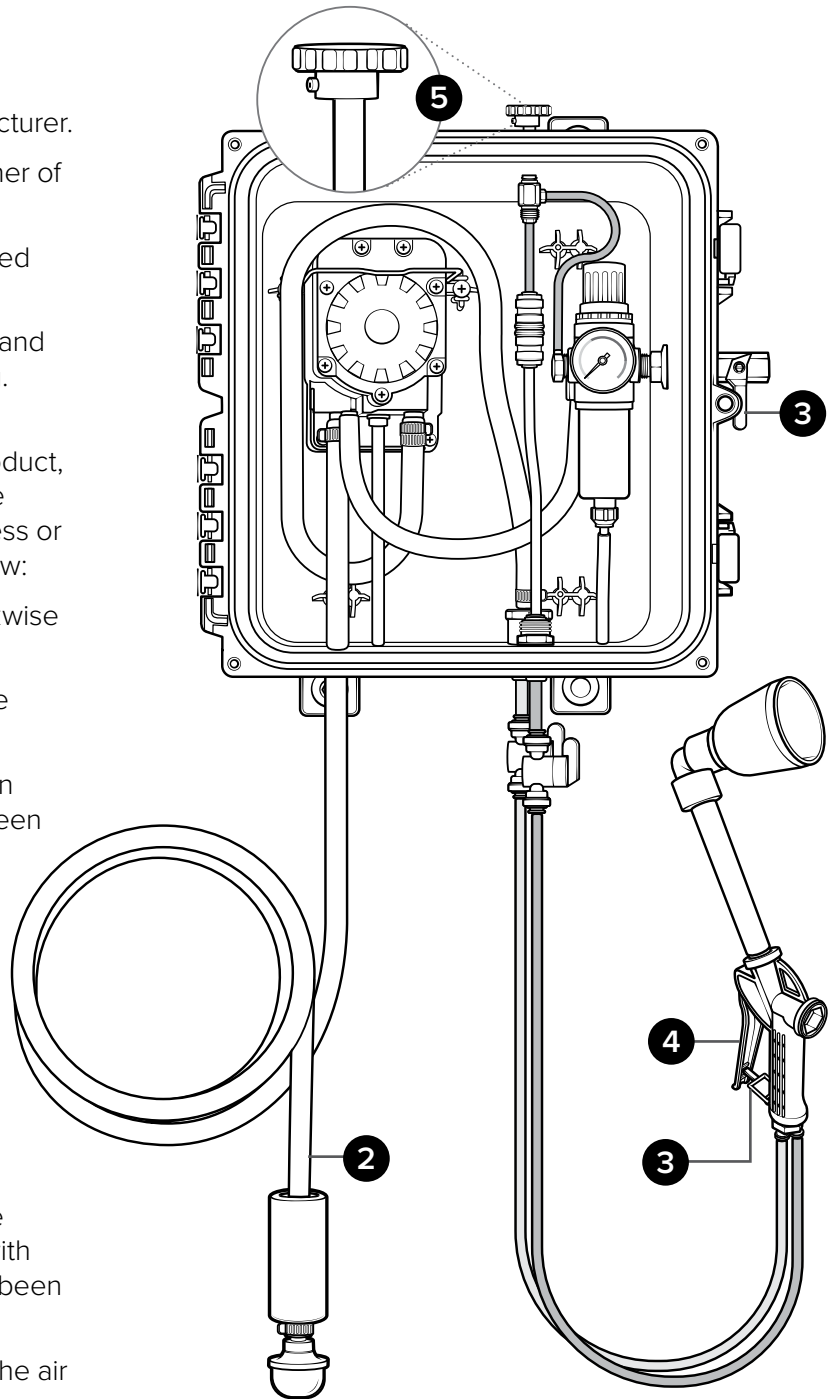

Service Guide

Maintaining Your Unit

To keep your foam unit operating properly, periodically perform the following maintenance procedures:

Note: Before performing any maintenance, ensure that the unit has been disconnected from the air supply and depressurized according to the After Use Instructions.

- Inspect the pump for wear and leaks.
- Inspect all hoses and tubing for leaks or excessive wear. Make sure all hose clamps are in good condition and properly secured.
- Replace the filter located within the air regulator as needed. Clean by unthreading the air regulator bowl from the air regulator.
- Check the chemical suction line and strainer for debris and clean as needed.
- Drain the air compressor tank on a regular basis to help extend pump life. An air source with a high moisture content will accelerate pump wear.

- Replace wadding inside discharge wand as needed. Replace wadding by performing the following steps:

1. Unthread wand from the trigger handle.
2. Remove the wadding inside the wand and discard.
3. Insert new wadding inside the wand.
4. Thread the wand back onto the trigger handle.

Note: If the air source has a high moisture content, you may wish to install a water separator before the unit.

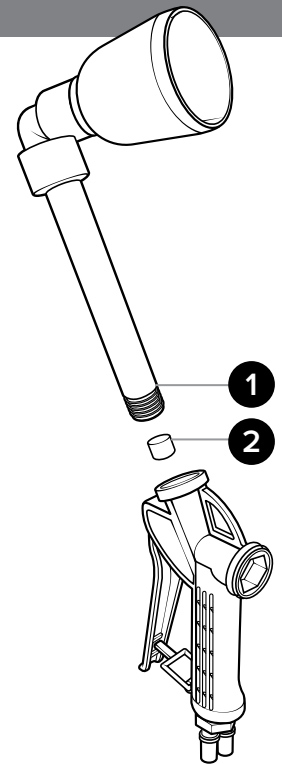

Troubleshooting Your Unit

If your unit is not operating properly, try using these troubleshooting tips:

- Check to ensure that the discharge tubing has no kinks that could obstruct fluid flow.
- Check the air regulator bowl and air filter for debris such as water, oil, or rust particles. Clean by unthreading the air regulator bowl from the air regulator.
- If the needle valve is open too far, the pump may cycle improperly due to lack of air pressure. If this occurs, close and readjust the needle valve as described in Operation Instructions.
- Make sure proper foaming chemical and concentration are being used.
- Check the wadding inside the wand for debris or if material is compressed and not allowing chemical solution to flow through. Clean or replace as needed as described in Maintenance Instructions.
- If air passes through the pump without cycling, the pump needs to be replaced.
- If solution backs up into the air regulator bowl, the check valve needs to be replaced.
- If foam comes out wet, no matter where the needle valve is positioned, the check valve may need to be replaced.
- Check for proper air pressure on the air gauge. The air regulator is factory set at 50 psi (3.4 bar). Operating range is 40 to 80 psi (2.8 to 5.5 bar) with 5 to 10 CFM (141.6 to 283.2 l/min).
- If the unit operates at a reduced pressure:
Check the air compressor supplying the unit. If the pressure is less than 40 psi (2.8 bar), turn the unit off until the compressor can catch up. If the air supply is 50 psi (3.4 bar) or above, check the air gauge, which should read near 50 psi (3.4 bar). If air gauge reads more or less than 50 psi (3.4 bar), adjust the pressure by turning the knob on the top of the air regulator.
Check the chemical suction line and strainer for debris or damage. Clean or replace as needed. To prevent damage to the unit, the strainer must always be used.

Parts

FI-WL-LVTL-CB

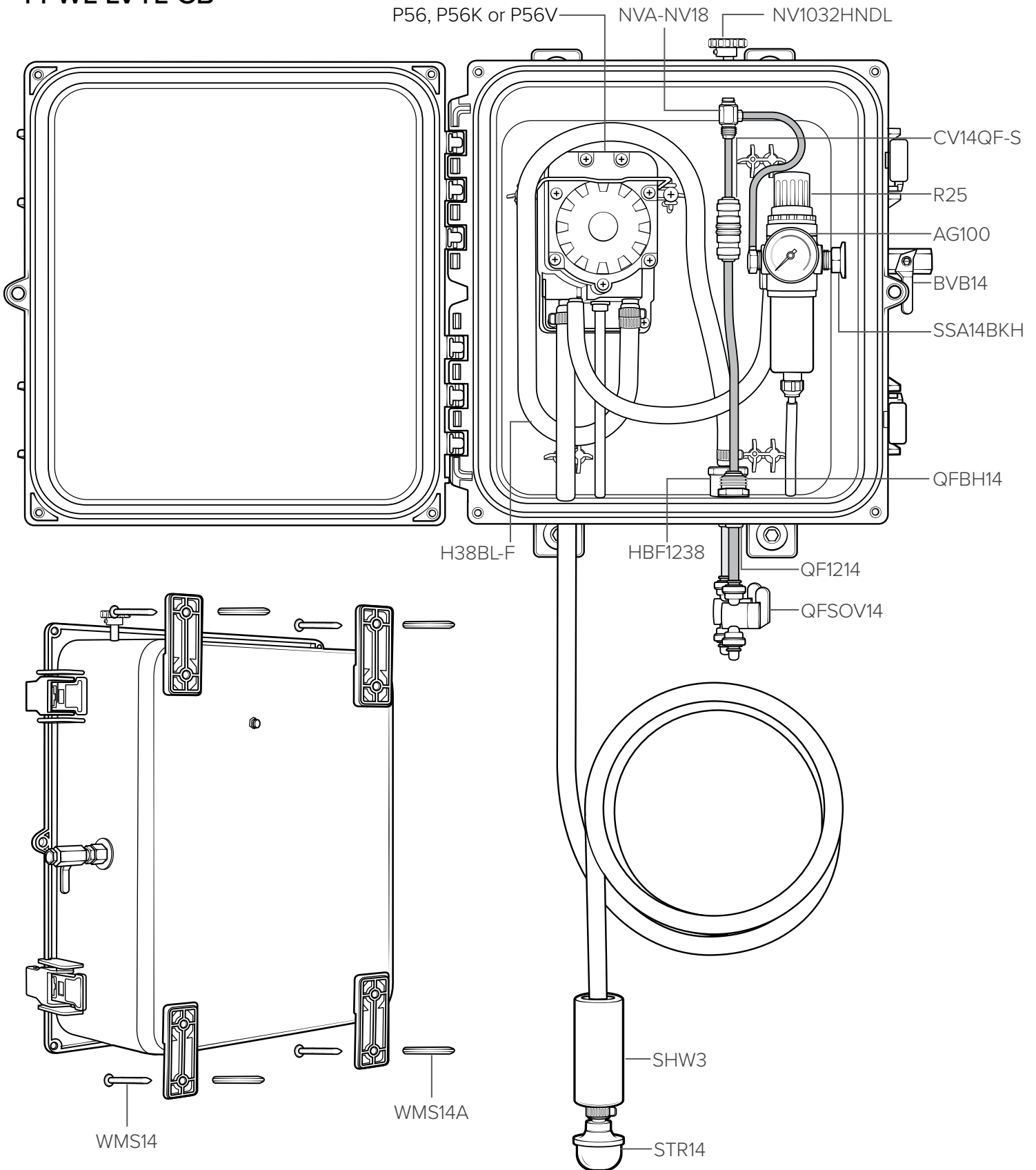

PSGATL4-DC-MX-CTB14-12-CV-DA DC-DA-2

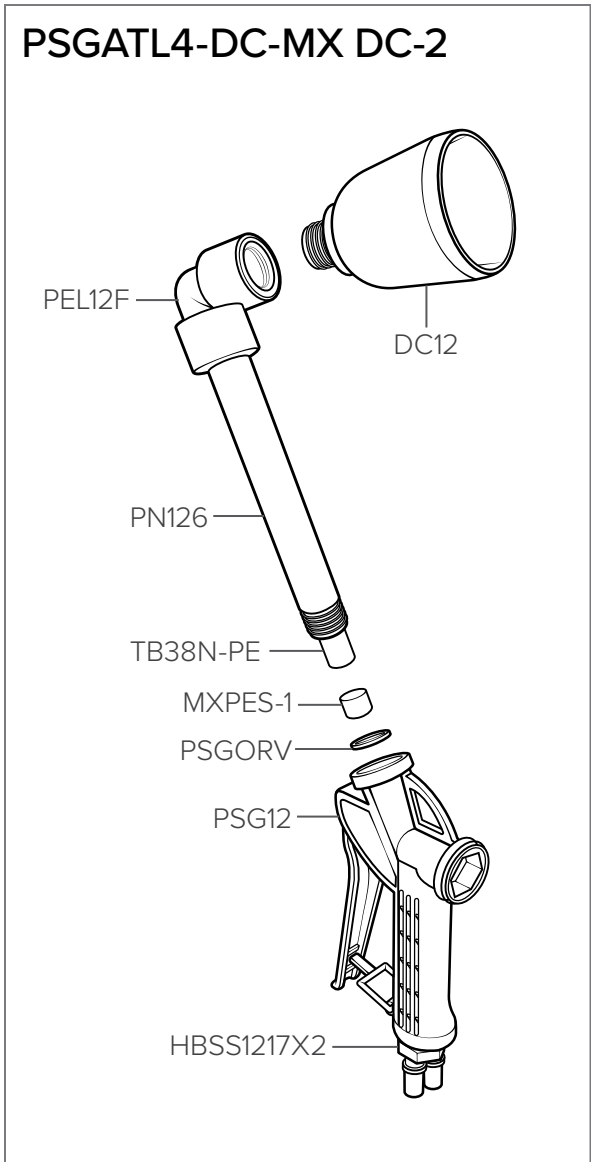
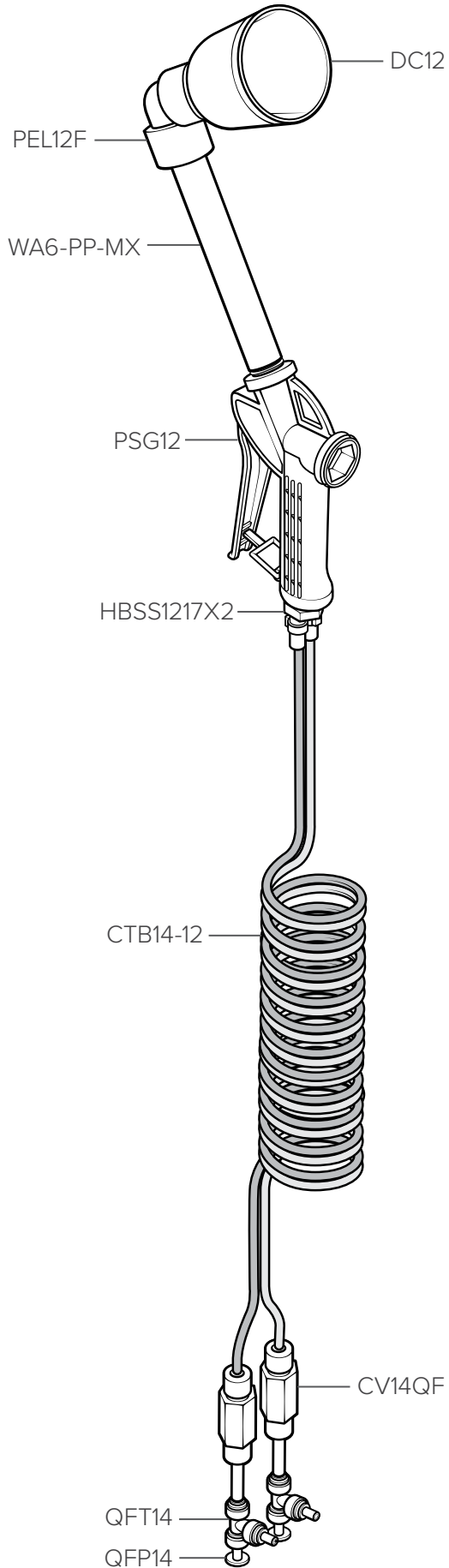

Item number	Description
AG100	Air gauge - 1/8 in. NPT - 0-100 PSI markings - dry model
BVB14	Air inlet valve 1/4 in. FPT X 1/4 in. FPT
CTB14-12	1/4 in. od coiled twin line bonded blue and red tube - polyurethane - 12 ft. reach
CV14QF	PVC quick connect check valve 1 lb. - Hastelloy spring - EP seals
CV14QF-S	1/4 tube x 1/4 tube CHK quick fit - small
DC12	Foam dip cup - 1/2 in. MPT- PP
PSGATL4-DC-MX	Poly spray gun assembly for twin line tube - 4 in. polypropylene wand with elbow - black - teat dip cup - mixing media - includes SS dual hose barb
PSGATL4-DC-MX-CTB14-12-CV-DA	Poly spray gun assembly with 12 ft. red and blue twin line tube - 4 in. polypropylene wand with elbow - black - teat dip cup - mixing media - includes SS dual hose barb, check valves, and drop assembly fittings
H14BL-F	1/4 in. id blue hose - hybrid TPE - available per ft.
H14CL-PV	1/4 in. id 3/8 in. od clear hose - PVC - available per ft.
H38BL-F	3/8 in. id blue hose - hybrid TPE - available per ft.
HBSS1217X2	Hose barb - stainless steel - 1/2 in. MPT x twin .170 in. barb
NVA-NV18	Needle valve assembly - 1/8 in. fitting - includes valve, handle, set screw
NV1032HNDL	Black handle for needle valve
P56	Pump with Santoprene seals - includes hose barbs, air fitting, and exhaust barb
P56K	Pump with Kalrez seals - includes hose barbs, air fitting, and exhaust barb
P56V	Pump with Viton seals - includes hose barbs, air fitting, and exhaust barb
PEL12F	1/2 in. female poly pipe elbow 90
PSG12	Poly spray gun with 2x 1/2 in. straight thread - gray handle with red clip - 316SS internal spring - includes o-ring (2)
PSGORV	O-ring for PSG12-VITON
PN126	1/2 in. NPT pipe nipple - black polypropylene - 6 in. long
QF1214	Quick fit 1/2 MPT x 1/4 OD tube - polypropylene
QFBH14	Bulkhead 1/4 in. tube polypropylene
QFP14	Plug, 1/4 in. - polypropylene
QFSOV14	Shut off valve 1/4 in. Tube - polypropylene
QFT14	Union tee 1/4 in. tube - polypropylene
R25	Regulator - air - 2x 1/4 in. FPT and 2x 1/8 in. FPT ports with bowl and filter - no gauge
SHW3	Suction hose weight - 15/16 in. id x 1 1/2 in. od x 3 1/4 in. long - PVC coated stainless
SSA14BKH	Bulkhead adapter - stainless steel - 1/4 in. NPT x 1/4 in. NPSM
SSSFN12	Serrated stainless steel flange nut - 1/2 in.
STR14	40 mesh suction line strainer 1/4 MNPT
WA6-PP-MX	Wand assembly - straight - 6 in. poly wand - mixing media - includes PE tube
MXPES-1	Mixing media - white polyester - wad - fine porosity - 1 in. diameter x 7/8 in. tall
WMS14	Wall mount screw - #14 x 1 1/4 in. - stainless steel - hex head slotted
WMS14A	Wall mount screw anchor - #14 x 1 1/4 in. - plastic - 5/16 in. drill size