

---

# **USER MANUAL**

**MODEL NUMBER:  
FI-WL-LVTL  
AND RELATED UNITS**

**Wall Mounted Twin Line Foam Unit**

---

**English (Original Instructions)**

---

## READ ALL INSTRUCTIONS BEFORE OPERATING EQUIPMENT

# WARNING



### Read this manual completely and understand the machine before operating or servicing it.

- Read all instructions before installing or operating unit.
- Always wear appropriate personal protective equipment (PPE) when operating or servicing unit.
- Always follow all chemical safety precautions and handling instructions provided by the chemical manufacturer and Material Safety Data Sheet (MSDS).
- If this unit is modified or serviced with parts not listed in this manual, the unit may not operate correctly.
- Never point the discharge wand at yourself, another person, or any object you do not want covered in chemical.
- Always depressurize unit after use (as described in the After Use Instructions). Always store unit depressurized, with the trigger handle in the closed position.
- Do not exceed an incoming air pressure of 100 psi (6.9 bar).
- Do not exceed a fluid temperature of 100°F (37.8°C).
- Always flush the unit with fresh water thoroughly when switching from an alkaline to an acid or an acid to an alkaline.
- Only use clean and dry air. Air must be filtered and free of moisture or pump life will be diminished. If needed, install an air dryer before unit.
- Do not use an air lubricator before the unit.
- Never use unit with hydrocarbons or flammable products.

### PROTECT THE ENVIRONMENT

Please dispose of packaging materials, old machine components, and hazardous fluids in an environmentally safe way according to local waste disposal regulations.



Always remember to recycle.

\*Specifications and parts are subject to change without notice.

Options		
	Pump Seal Material	
FI-WL	Santoprene (standard)	LVTL
	Viton ( <b>V</b> )	
	Kalrez ( <b>K</b> )	
Add bold option codes to item number as shown. For standard options, no option code is needed.		
<b>Examples:</b> <ul style="list-style-type: none"> <li>• FI-WL-LVTL (standard unit with Santoprene pump seals)</li> <li>• FI-WLV-LVTL (unit with Viton pump seals)</li> </ul>		

## READ ALL INSTRUCTIONS BEFORE OPERATING EQUIPMENT

REQUIREMENTS	
Compressed air requirements	40-80 psi (2.8-5.5 bar) with 3-5 cfm (85-141.6 l/min)
Liquid temperature range	40-100°F (4.4-37.8°C)
Chemical compatibility	Chemical products used with this equipment must be formulated for this type of application and compatible with unit materials and pump seals. For more information on chemical compatibility, consult the manufacturer or MSDS for your product or contact our customer service department.

SPECIFICATIONS	
Power type	Compressed air
Chemical pickup type	Draws from pre-mixed solution
Number of products unit can draw from	One product
Suction line length/diameter	8 ft. (2.4 m) hose with 3/8 in. (9.5 mm) inside diameter)
Discharge hose diameter/length	25 ft. (7.6 m) twin line tubing, with 1/4 in. (6.4 mm) outside diameter (coiled and bonded)
Discharge wand/tip type	Polypropylene trigger handle with 65° fan tip
Output distance	4-6 feet (1.2-1.8 m)
Output volume	6 gal/min (22.7 L/min) of foam
Flow rate*	Less than 2 gal/min (7.6 L/min)
Pump seals	Santoprene, Viton, or Kalrez

\*Dilution rates and flow rates given are based on chemical with viscosity of water and factory air pressure settings.

## READ ALL INSTRUCTIONS BEFORE OPERATING EQUIPMENT

### Installation Instructions:

1. Remove all components from packaging.
2. Select desired area to mount the control box.  
**Note:** We recommend mounting the control box at a height of 8 feet or less. The chemical suction line must reach the bottom of the chemical container. The bottom of the chemical container should not be positioned higher than the bottom of the control box.
3. Attach the control box mounting feet to the back of the control box, using the 4 screws provided in the parts package.
4. Mount the control box to the wall using 4 of the screws and plastic anchors provided in the parts package.  
**Note:** To drill holes for the plastic anchors, use a  $\frac{5}{16}$  inch drill bit.
5. Connect the coiled tubing to the bulk heads - red tube to RED label, blue tube to BLUE label.
6. Connect the air inlet hose barb provided in the parts package to the air inlet valve located on the side of the control box. Then attach a  $\frac{3}{8}$  inch I.D. air line from your air compressor to the air inlet hose barb, and secure it with the smaller hose clamp provided in the parts package.

### Operation Instructions:

1. Follow all instructions from chemical manufacturer. Place the chemical suction line into a container of pre-mixed chemical solution.
2. With the discharge trigger handle in the closed position, open the air inlet valve.
3. To start foaming, point discharge handle assembly at area you wish to foam and squeeze the trigger handle to begin foaming. Release the trigger handle to stop foaming.
4. While the unit is running and discharging product, adjust the needle valve, located inside the control box, as needed to regulate the wetness or dryness of the foam following the steps below:
  - a. Close needle valve completely in clockwise direction.
  - b. Open needle valve in counter-clockwise direction 2 complete turns.
  - c. Continue to open needle valve in  $\frac{1}{4}$  turn increments, allowing 30 seconds between adjustments, until desired consistency of foam is achieved.

### After Use Instructions:

We recommend flushing the discharge hose and depressurizing the unit after each use.

1. Place the chemical suction line into a container of water.
2. With the unit running, squeeze the discharge trigger handle, and allow the unit to be flushed with fresh water thoroughly until all chemical has been discharged from the system.
3. Shut off the air supply to the unit by closing the air inlet valve.
4. Squeeze the trigger handle to relieve any pressure remaining in the unit.
5. Release the trigger handle after all pressure has been relieved from the unit. Store the unit with the trigger handle in the closed position.

### Maintenance Instructions:

To keep your foam unit operating properly, periodically perform the following maintenance procedures:

**Note:** Before performing any maintenance, ensure that the unit has been disconnected from the air supply and depressurized according to the "After Use Instructions" above.

- Inspect the pump for wear and leaks.
- Inspect all hoses and tubing for leaks or excessive wear. Make sure all hose clamps are in good condition and properly secured.
- Replace the filter located within the air regulator as needed. Clean by unthreading the air regulator bowl from the air regulator.
- Check the chemical suction line and strainer for debris and clean as needed.
- Replace wadding inside discharge wand as needed. Replace wadding by following steps below:
  1. Unthread wand from trigger handle.
  2. Remove the wadding inside the wand and discard.
  3. Insert new wadding inside the wand.
  4. Thread the wand back onto the trigger handle.
- Drain the air compressor tank on a regular basis to help extend pump life. An air source with a high moisture content will accelerate pump wear. **Note:** If the air source has a high moisture content, you may wish to install a water separator (sold separately) before the unit.

## READ ALL INSTRUCTIONS BEFORE OPERATING EQUIPMENT

### Troubleshooting Instructions:

- Check to ensure that the discharge tubing has no kinks that could obstruct fluid flow.
- Check the air regulator bowl and air filter for debris such as water, oil, or rust particles. Clean by unthreading the air regulator bowl from the air regulator.
- If the needle valve is open too far, the pump may cycle improperly due to lack of air pressure. If this occurs, close and readjust the needle valve as described in Operation Instruction #4.
- Make sure proper foaming chemical and concentration are being used.
- Check the wadding for debris or if material is compressed and not allowing chemical solution to flow through. Clean or replace as needed as described in Maintenance Instructions.
- If air passes through the pump without cycling, the pump needs to be replaced.
- If solution backs up into the air regulator bowl, the check valve needs to be replaced.
- If foam comes out wet, no matter where the needle valve is positioned, the check valve may need to be replaced.
- Check for proper air pressure on the air gauge. The air regulator is factory set at 50 psi (3.4 bar). Operating range is 40 to 80 psi (2.8 to 5.5 bar) with 5 to 10 CFM (141.6 to 283.2 l/min).
- If the unit operates at a reduced pressure:
  - o Check the air compressor supplying the unit. If the pressure is less than 40 psi (2.8 bar), turn the unit off until the compressor can catch up.
  - o If the air supply is 50 psi (3.4 bar) or above, check the air gauge, which should read near 50 psi (3.4 bar). If the air gauge reads more or less than 50 psi (3.4 bar), adjust the pressure by turning the knob on the top of the air regulator.
- Check the chemical suction line and strainer for debris or damage. Clean or replace as needed. To prevent damage to the unit, the strainer must always be used.

## READ ALL INSTRUCTIONS BEFORE OPERATING EQUIPMENT

### PARTS DIAGRAMS - UNITS WITH STANDARD FITTINGS

#### CONTROL BOX ASSEMBLY

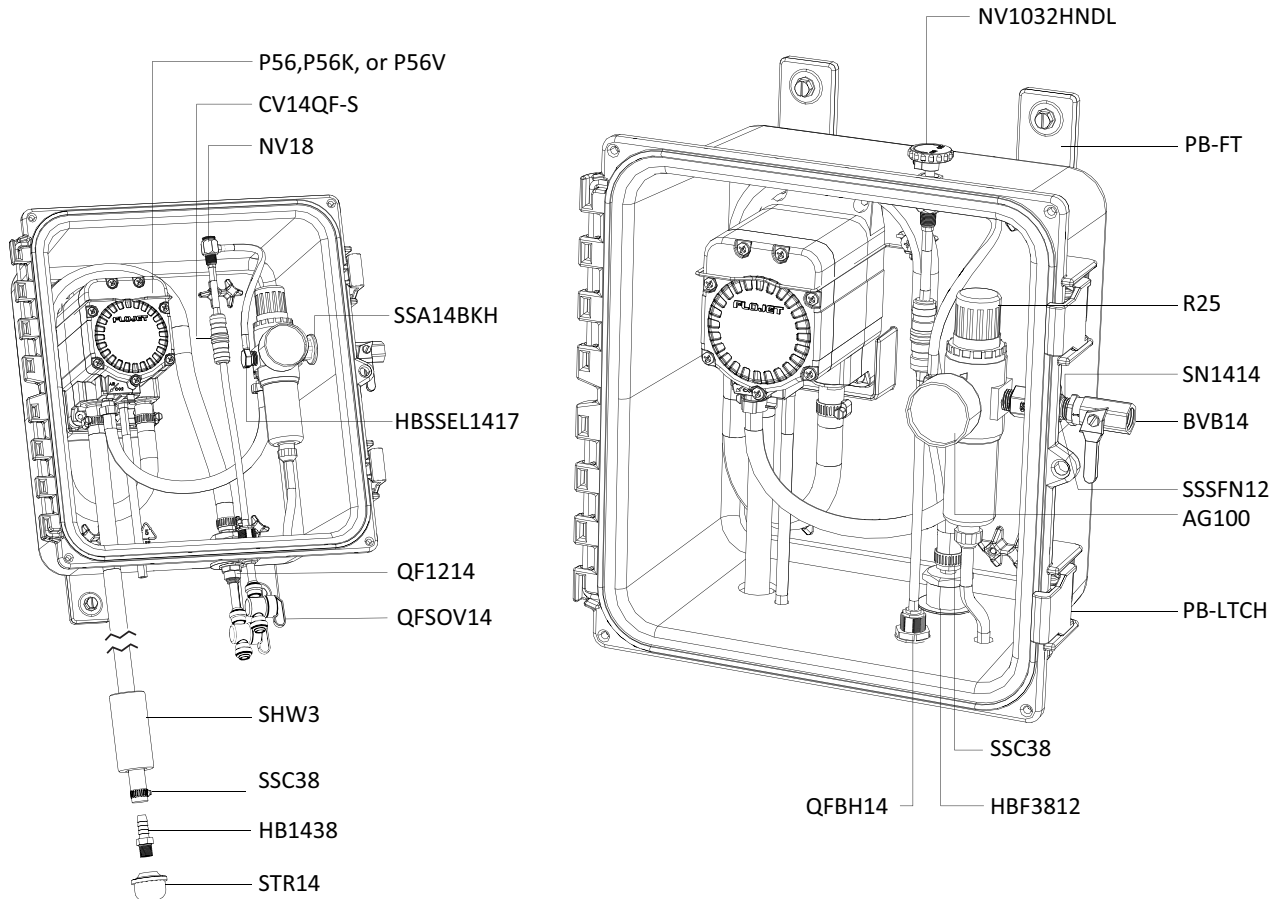

#### COILED TUBING AND FAN TIP FOAM WAND ASSEMBLY

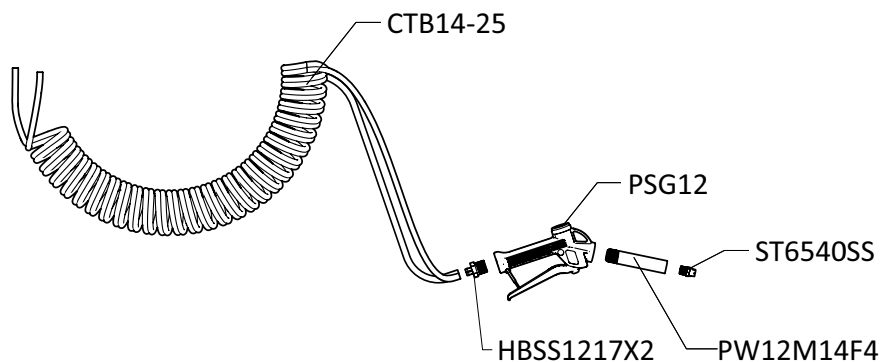

#### OPTIONAL COMPONENT WATER SEPARATOR ASSEMBLY ITEM NUMBER: WSA-20CFM

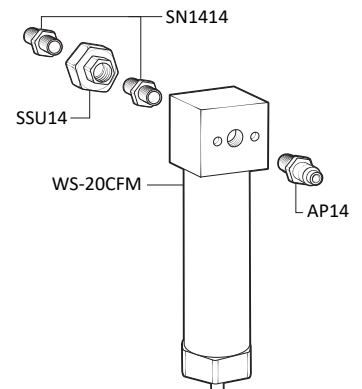

## READ ALL INSTRUCTIONS BEFORE OPERATING EQUIPMENT

ITEM NUMBER	DESCRIPTION
AG100	AIR GAUGE - 1/8IN NPT - 0-100 PSI MARKINGS - DRY MODEL
BRKT-P56	PUMP BRACKET- STAINLESS STEEL
BVB14	AIR INLET VALVE-1/4IN FPT X 1/4IN FPT
CTB14-25	1/4IN OD COILED TWIN LINE BONDED BLUE AND RED TUBE - POLYURETHANE - 25FT REACH
CV14QF-S	1/4 TUBE X 1/4 TUBE CHK QUICK FIT-SMALL
EC14	EAR CLAMP - OETIKER - STAINLESS STEEL - FOR 1/4IN HOSE
EC38TB	EAR CLAMP - OETIKER - STAINLESS STEEL - FOR 3/8IN OD TUBE
FW12NPT	FLAT WASHER FOR 1/2IN NPT - STAINLESS - 0.88IN ID X 1.5IN OD X 0.05IN THK
FW12NPT-THK	FLAT WASHER FOR 1/2IN NPT - THICK - STAINLESS - 0.88IN ID X 1.5IN OD X 0.12IN THK
H14BL-F	1/4IN ID BLUE HOSE-HYBRID TPE-AVAILABLE PER FT
H14CL-PV	1/4IN ID 3/8IN OD CLEAR HOSE - PVC - AVAILABLE PER FT
H316CL-PV	3/16IN ID 5/16IN OD CLEAR HOSE - PVC - AVAILABLE PER FT
H38BL-F	3/8IN ID BLUE HOSE-HYBRID TPE-AVAILABLE PER FT
HB1438	1/4in MPT X 3/8in HOSE BARB (PLASTIC)
HBB103217	HOSE BARB 10-32 MPT X B4 FITTING
HBB103217W	FIBER WASHER FOR HBB103217 - W/ BARB
HB1238	HOSE BARB - POLYPROPYLENE - 1/2IN FPT X 3/8IN BARB
HBSS1217X2	HOSE BARB - STAINLESS STEEL - 1/2IN MPT X TWIN .170IN BARB
HBSS1438	HOSE BARB - STAINLESS STEEL - 1/4IN MPT X 3/8IN BARB
HBSEL1417	HOSE BARB - STAINLESS STEEL - ELBOW - 1/4IN MPT X .17IN BARB
HBSEL1814	HOSE BARB - STAINLESS STEEL - ELBOW - 1/8IN MPT X 1/4IN BARB
MXPES-34	MIXING MEDIA - WHITE POLYESTER - WAD - FINE POROSITY - 3/4IN DIAMETER X 7/8IN TALL
NV18-A	NEEDLE VALVE ASSEMBLY - VALVE, HANDLE, SET SCREW
NV1032HNDL	BLACK HANDLE FOR NEEDLE VALVE
NV1032SETS	SET SCREW FOR HANDLE
NV18	NEEDLE VALVE-1/8 IN MPT-10-32F-VALVE ONLY-NO SETS-NO HANDLE
PBA-12117	POLY BOX ASSEMBLY - 12IN X 11IN X 7IN - GRAY POLYPROPYLENE - INCLUDES BRAND LABEL AND MOUNTING HARDWARE
PB12117-LID	POLY BOX LID - GRAY POLYPROPYLENE - FOR PBA-12117 - INCLUDES PB-GSKT ROPE SEAL
PB12117-BOX	POLY BOX - GRAY POLYPROPYLENE - FOR PBA-12117

PB-FT	POLY BOX FOOT - GRAY POLYPROPYLENE - FOR PBA-12117 AND PBA-16138
PB-LTCH	POLY BOX LATCH - GRAY POLYPROPYLENE - TWO PIECES ASSEMBLED - FOR PBA-12117 AND PBA-16138
PB-PIN	STAINLESS STEEL HINGE PIN FOR PB16138 AND PB12117
P56	5700 PUMP WITH SANTOPRENE SEALS - INCLUDES HOSE BARBS, AIR FITTING, AND AIR PORT
P56K	5700 PUMP WITH KALREZ SEALS - INCLUDES HOSE BARBS, AIR FITTING, AND AIR PORT
P56V	5700 PUMP WITH VITON SEALS - INCLUDES HOSE BARBS, AIR FITTING, AND AIR PORT
HBB14P	1/4IN HOSE BARB-BRASS-FOR G57/P56 AIR FITTING WITH O-RING
HB5638	HOSE BARB FOR P56 PUMP
HB5638K	HOSE BARB FOR P56K PUMP
HB5638V	HOSE BARB FOR P56V PUMP
PSG12	POLY SPRAY GUN WITH 2X 1/2IN STRAIGHT THREAD - GRAY HANDLE WITH RED CLIP - 316SS INTERNAL SPRING - INCLUDES 2X O-RING
PSGORV	O-RING FOR PSG12-VITON
PW12M14F4	1/2IN NPT AND 1/4IN FNPT WAND - BLACK UHMW - 4IN LONG
QF1214	QUICK FIT-1/2 MPT X 1/4 OD TUBE-POLYPROPYLENE
QFBH14	BULKHEAD 1/4in TUBE POLYPROPYLENE
QFSOV14	SHUT OFF VALVE 1/4in TUBE - POLYPROPYLENE
R25	REGULATOR - AIR - 2X 1/4IN FPT AND 2X 1/8IN FPT PORTS WITH BOWL AND FILTER - NO GAUGE
S1012-HL	SCREW - #10 X 1/2IN - STAINLESS STEEL - ROUND HEAD PHILLIPS - HILO THREAD
S1034-FH-HL	SCREW - #10 X 3/4IN - STAINLESS STEEL - FLAT HEAD PHILLIPS - HILO THREAD
SHW3	SUCTION HOSE WEIGHT - 15/16IN ID X 1 1/2IN OD X 3 1/4IN LONG - PVC COATED STAINLESS
SN1414	STAINLESS HEX NIPPLE 1/4 MPT X 1/4 MPT
SSA14BKH	BULKHEAD ADAPTER - STAINLESS STEEL - 1/4 IN. NPT X 1/4 IN. NPSM
SSC38	SCREW BAND CLAMP - STAINLESS STEEL - FOR 3/8IN HOSE
SSSFN12	SERRATED STAINLESS STEEL FLANGE NUT - 1/2 IN.
ST6540SS	SPRAY TIP-65 DEGREE-4.0 GPM-STAINLESS-1/4 MPT
STR14	40 MESH SUCTION LINE STRAINER 1/4 FNPT
TB14BL-PU	1/4IN OD BLUE TUBE - POLYURETHANE - AVAILABLE PER FT
TB38N-PE	3/8IN OD NATURAL TUBE - POLYETHYLENE - AVAILABLE PER FT
WMS14	WALL MOUNT SCREW - #14 X 1 1/4IN - STAINLESS STEEL - HEX HEAD SLOTTED
WMS14A	WALL MOUNT SCREW ANCHOR -#14 X 1 1/4IN - PLASTIC - 5/16IN DRILL SIZE
WSA-20CFM	WATER SEPARATOR ASSEMBLY-20CFM-1/4IN FPT PORTS-INCLUDES AIR PLUG, UNION FITTINGS