

---

# USER MANUAL

**MODEL NUMBER:  
FOG-IT-DS**

**110VAC ELECTRIC FOG UNIT WITH DIGISET  
TIMER**

---

**English (Original Instructions)**

---

## READ ALL INSTRUCTIONS BEFORE OPERATING EQUIPMENT



# WARNING



Read this manual completely and understand the machine before interacting with it.

- Do not alter or modify equipment.
- Use only genuine replacement parts from original manufacturer.
- Use equipment only for its intended purpose.
- Inspect unit before each use. Tighten any loose connections. Be sure hose is not cracked or frayed and shows no sign of swelling. Repair or replace worn or damaged parts immediately.
- Do not use unit if damaged or broken.
- Do not exceed maximum air or fluid pressure for unit (refer to Technical Data).
- Do not use with flammable chemicals or hydrocarbons.
- Use only chemical products that are formulated for this type of application and compatible with unit materials and pump seals. For information about your chemical product, request chemical Safety Data Sheet (SDS) from your chemical supplier.
- Depressurize unit (as described in the After Use Instructions) when not in use and before disassembling.
- Always flush the unit with fresh water when switching from an alkaline to an acid or an acid to an alkaline.
- Before performing any maintenance on this unit, disconnect the unit from the electrical power source and depressurize.
- Make sure all electric power cords are located so that they cannot be stepped on, tripped over, or otherwise subjected to damage or stress.
- Pump, valves, and containers must be properly grounded when handling flammable fluids and whenever discharge of static electricity is a hazard.

### PROTECT THE ENVIRONMENT

Please dispose of packaging materials, old machine components, and hazardous fluids in an environmentally safe way according to local waste disposal regulations.



Always remember to recycle.

Specifications and parts are subject to change without notice.

### TIMER ADJUSTMENT INSTRUCTIONS

The TR120DS-A is an adjustable repeat cycle timer with the ON time operating first. ON and OFF times can range from 1 second to 511 minutes.

#### To set the timer:

1. Starting with the OFF time, move the top dip switch to the left for MIN (minutes) or to the right for SEC (seconds) to select the desired time interval.
2. The next 9 dip switches will be used to control the total active time. To the left is active and to the right is inactive. Combine the numbers of active dip switches to achieve the desired time. The increments are 1, 2, 4, 8, 16, 32, 64, 128, 256.
3. Repeat the above steps for the ON time setting.
4. Timer indicator light will appear red when unit output is off. The indicator turns green when output is on.

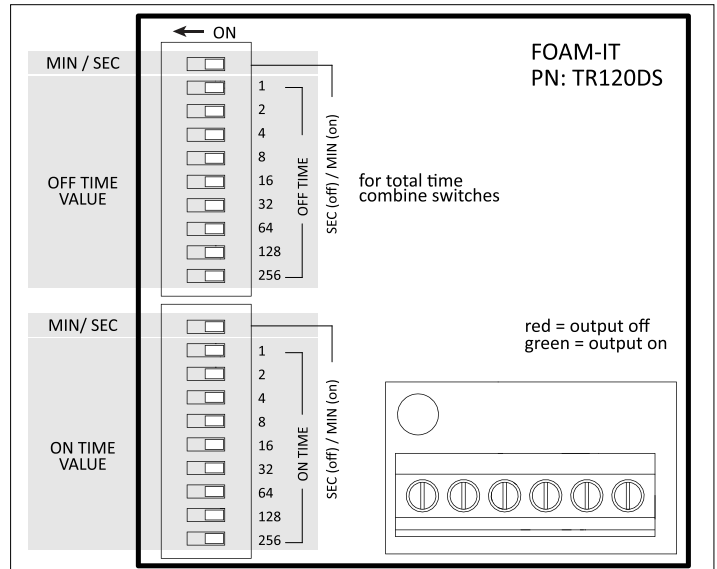

## READ ALL INSTRUCTIONS BEFORE OPERATING EQUIPMENT

REQUIREMENTS	
Liquid temperature range	40-100°F (4.4-37°C)
Electrical requirements	120 VAC at 60 Hz, 2 amps (GFCI protected outlet)
Operating voltage	120 VAC
Chemical Compatibility	Chemical products used with this equipment must be formulated for this type of application and compatible with unit materials and pump seals. For more information on chemical compatibility, consult the manufacturer or SDS for your product or contact our customer service department.

SPECIFICATIONS	
Power type	Electricity
Chemical pickup type	Draws from pre-mixed solution
Number of products unit can draw from	One product
Suction line length/diameter	8 ft. (2.4 m) hose with 3/8 in. (9.5 mm) inside diameter
Output distance	3-5 ft. (0.9-1.5 m)
Output volume	7.8 oz/min (0.23 l/min) per nozzle
Flow rate*	7.8 oz/min (0.23 l/min) per nozzle
Pump seals	Santoprene/EPDM
Timer operation type	Repeat cycle
Droplet size	Very fine
Nozzle type	Hollow cone spray tip
Number of nozzles	One control box can support up to thirty nozzle assemblies
Distance from nozzles to control box	The combined distance between the control box and the nozzle(s) must equal 200 ft. (61 m) or less
Tubing/fitting sizes	Designed for use with 1/4 in. (6.4 mm) outside diameter tubing between control box and nozzle(s)

\*Dilution rates and flow rates given are based on chemical with viscosity of water and factory air pressure settings.

## READ ALL INSTRUCTIONS BEFORE OPERATING EQUIPMENT

### Installation Instructions:

1. Remove all components from packaging.
2. Select an area to mount the control box.  
**Note:** The control box should be mounted to a vertical wall. We recommend mounting the control box at a height of 6 feet or less. The chemical suction line must reach the bottom of the chemical container. The bottom of the chemical container should not be positioned higher than the bottom of the control box.
3. Attach the control box mounting feet to the back of the control box, using the four screws provided in the parts package.
4. Mount the control box to the wall using four of the screws and plastic anchors provided in the parts package.  
**Note:** To drill holes for the plastic anchors, use a  $\frac{3}{16}$  inch drill bit.
5. Install quick connect elbows to outlet fittings on bottom of control box.
6. Mount the fog nozzle assemblies in desired locations.
7. Run  $\frac{1}{4}$  inch tubing from control box outlet to the fog nozzles.
8. Install pressure relief tubing to the quick connect closest to the wall.  
**Note:** this line should be dispensed back into the chemical container.
9. Set the timer for the desired on time and off time, as described in the Timer Adjustment Instructions.
10. With the power switch in the OFF position, plug the unit into a GFCI protected 120VAC power outlet.
11. Follow all instructions from chemical manufacturer and place the end of the chemical intake line into container of pre-diluted chemical solution.
12. Place the priming valve line and pressure relief line in the chemical container.

### Operation Instructions:

1. Prepare area to be fogged.
2. Verify the ON/OFF times on the timer are set per the application requirements.
3. To activate the unit, turn the power switch to the ON position. The unit will begin cycling through the run and delay time intervals set on the timer, beginning with the run time.
4. With the pump running, open the priming valve until solution begins to flow through the line. Once solution is flowing through the line close the priming valve.
5. Begin to adjust the pressure relief valve until the liquid gauge reaches below 150 psi.  
**Note:** If the pump is making a hammering sound the pressure relief will need to be opened further. Slowly open the pressure relief valve until the pump is no longer hammering.

### Troubleshooting Instructions:

1. Check the chemical suction line and strainer for debris or damage. Clean or replace as needed. To prevent damage to the unit, the strainer must always be used.
2. If pump is not drawing chemical, repeat steps 4 and 5 from Operation Instructions.
3. If pump is hammering loudly, adjust pressure relief valve until the pump equalizes, around 75 to 100 PSI.
4. If product is not being dispensed through a fog nozzle, disassemble the nozzle and inspect for any debris or build up.
5. If unit is not turning on but power is supplied to the unit, confirm the timer setting is correct.

**READ ALL INSTRUCTIONS BEFORE OPERATING EQUIPMENT**

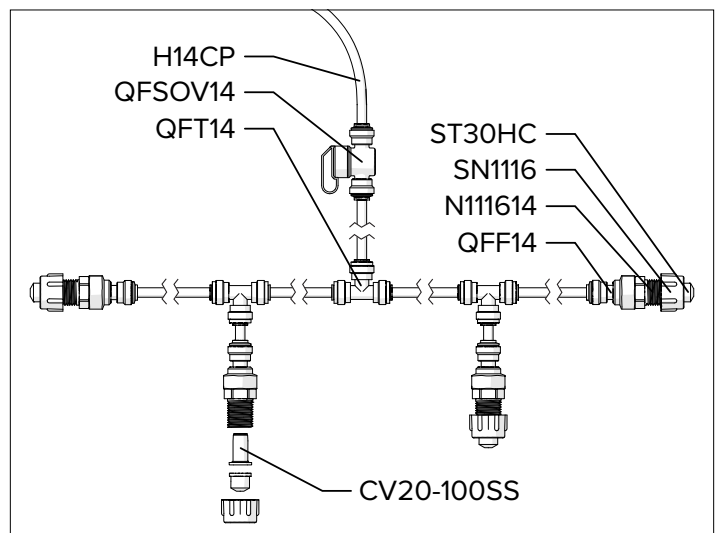
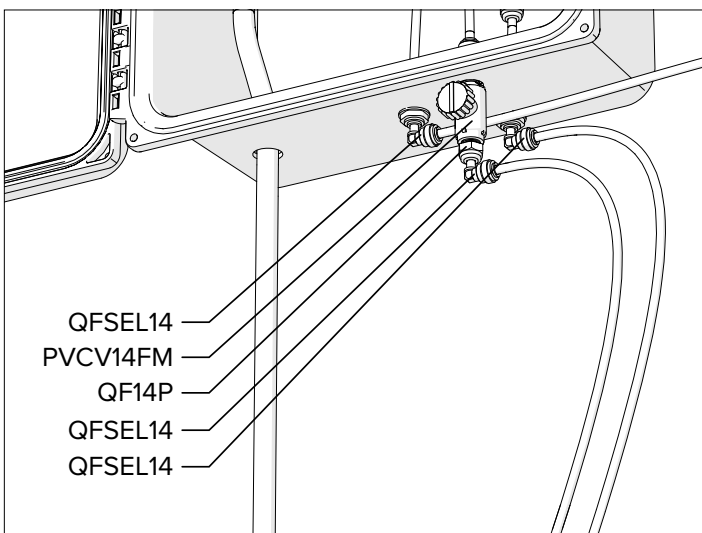
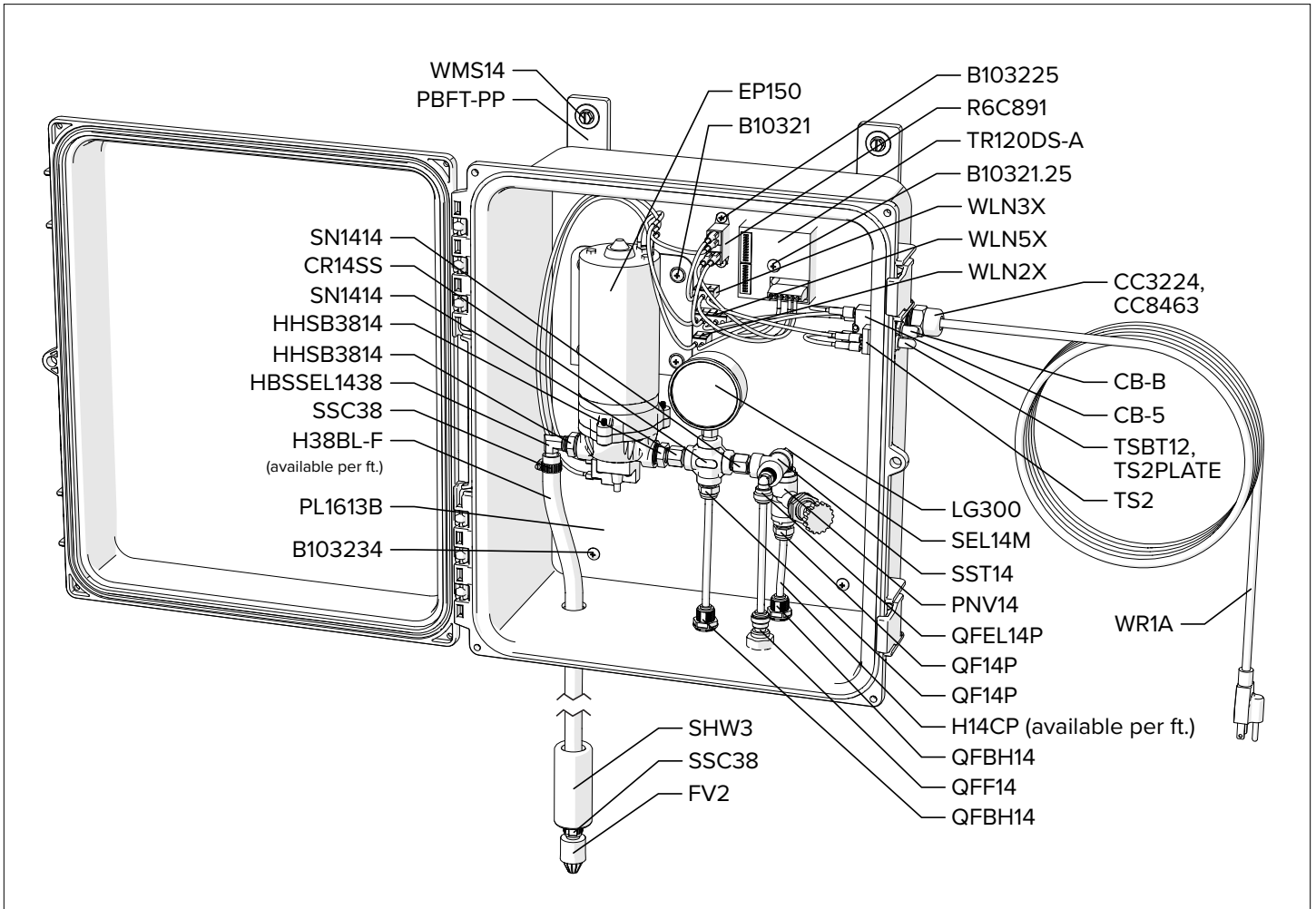

## READ ALL INSTRUCTIONS BEFORE OPERATING EQUIPMENT

ITEM NUMBER	DESCRIPTION
B10321	10-32 X 1 PHIL TRUSS MACH SCR 18-8
B10321.25	10-32 X 1 1/4 PHIL TRUSS MACH 18-8
B103225	10-32 X 1/4in PHIL MACH SCREW 18-8
B103234	10-32 X 3/4 PHIL TRUSS MACH SCR 18-8
CB-5	5 AMP CIRCUIT BREAKER-UL1077
CB-B	CLEAR BOOT FOR CIRCUIT BREAKER
CC3224	1/2 NPT STRAIN RELIEF GRIP FITTING - BLACK
CC8463	1/2 NPT LOCKNUT - BLACK
CV20-100SS	100 MESH 20# BALL CHECK STRAINER-POLYPROPYLENE
EP150	PMP 115VAC 150 PSI N/E/
FV2	FOOT VALVE, VITON, BLACK
H14CP	1/4IN OD POLYETHYLENE TUBING-NATURAL COLOR - Available per ft.
H38BL-F	3/8IN BLUE HOSE-HYBRID TPE-AVAILABLE PER FT
HBSSEL1438	STAINLESS HOSE BARB 1/4 MPT X 3/8 BARB ELBOW
HHSB3814	HEX HEAD STAINLESS BUSHING 3/8 MPT X 1/4 FPT
LG300	1/4in SS LIQUID GUAGE W/ 1/4in 0-300
N111614	11/16 X 1/4 NIPPLE
PB16138	POLYPROPYLENE CONTROL BOX - WORKING DIMS 16x13x8 - PUMP MOUNT
PBFT-PP	MOUNTING FEET FOR POLYBOX - PB16138 - POLYPROPYLENE
PB-LTCH	POLY BOX LATCH FOR PB16138 AND PB12117
PB-PIN	STAINLESS STEEL HINGE PIN FOR PB16138 AND PB12117
PL1613B	PLATE FOR PB16138 (BLANK) - PL-4X8
PNV14	PVC 586-4F4F-T, NEEDLE
PVCV14FM	PVC BALL VALVE-1/4FPT X 1/4MPT-VITON SEALS
QF14P	QUICK FIT-1/4 MPT X 1/4 OD TUBE-POLYPROPYLENE
QFBH14	BULKHEAD 1/4in TUBE POLYPROPYLENE

QFEL14P	FIXED ELBOW 1/4in TUBE X 1/4in MPT - POLYPROPYLENE
QFF14	FEMALE ADAPTER 1/4in TUBE X 1/4in NPTF POLYPROPYLENE
QFSEL14	PLUG-IN ELBOW 1/4in TUBE X 1/4in TUBE - POLYPROPYLENE
QFISOV14	SHUT OFF VALVE 1/4in TUBE - POLYPROPYLENE
QFT14	UNION TEE 1/4in TUBE - POLYPROPYLENE
RLY-120VAC-NBASE	RELAY 120VAC-NO BASE-PANEL MOUNTED
S103238SS	10-32 x 3/8 PHILLIPS PAN 18-8 SS
S1034FHL	10 X 3/4 PHIL FLAT HI-LO THRD SCREW 18-8
SEL14M	STAINLESS ELBOW 1/4IN MPT X 1/4IN MPT
SHW3	3in LONG COATED WEIGHT
SN1116	POLY SWIVEL NUT 11/16
SN1414	STAINLESS HEX NIPPLE 1/4 MPT X 1/4 MPT
SSC38	STAINLESS SCREW BAND CLAMP FOR 3/8 IN HOSE
SSCR14	SS CROSS 1/4 IN FPT
SST14	STAINLESS TEE 1/4 FPT
STBHC3	SPRAY TIP-BUTTON STYLE-HOLLOW CONE-3.0 GAL/HR
TR120DS-A	REPEAT CYCLE TIMER - ADJUSTABLE DIGI-SET - 120 VAC PART
TS2	TOGGLE SWITCH SPST
TS2PLATE	ON/OFF SWITCH PLATE
TSBT12	TOGGLE SWITCH BOOT
WCB14F	14-16 - 1/4 FEM INSULATED CONNECTOR
WCB18F	22-18 AWG - 1/8 FEM INSULATED CONNECTOR
WLN2X	WIRE LEVER NUT 2X
WLN3X	WIRE LEVER NUT 3X
WMS14	14 X 1 1/4 HEX W/H SMS SLOTT, S/S
WMS14A	5/16 X 1 1/2 STRAIGHT PLASTIC ANCHOR
WR1A	18/3 POWER CORD WITH GROUNDED PLUG-9FT LONG-BLACK