

1.3 Gallon Pump-Up Spray Unit

User Manual

SP5.0L | SP5.0L-PSG

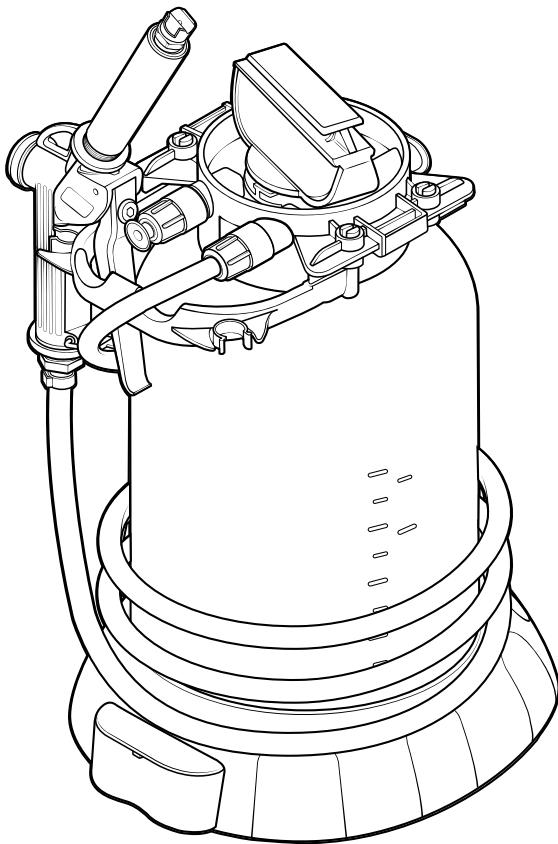

SP5.0L-PSG

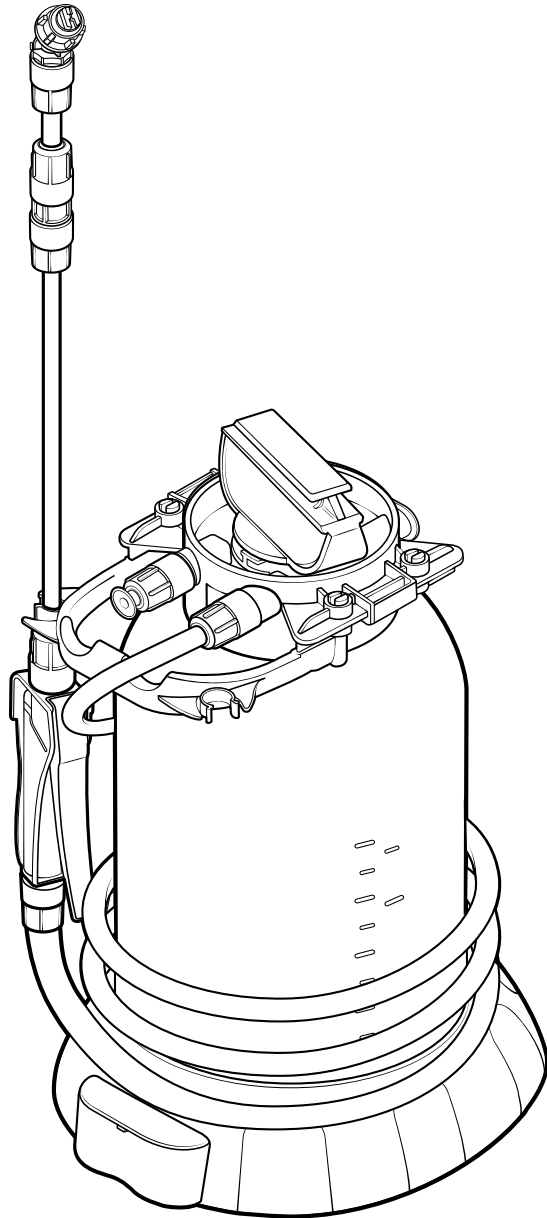

SP5.0L

READ ALL INSTRUCTIONS BEFORE USING OR SERVICING THIS UNIT. KEEP THIS MANUAL IN A LOCATION THAT IS READILY AVAILABLE TO USERS AND SERVICE TECHNICIANS.

English (Original Instructions)



Scan this code
for user manual

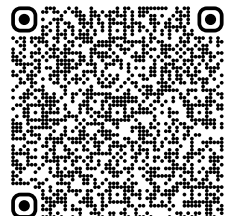

Safety

WARNING

PEOPLE OR OBJECTS CAN BE HURT OR DAMAGED IF THIS UNIT IS NOT USED CORRECTLY!



Failure to read all the instructions before operating the unit may result in personal injury or death from the improper use or the chemical solution. Anyone handling, operating or using the unit must read and understand the instructions in the manual. The buyer assumes all responsibility for safety and proper use in accordance with the instructions.



Using or servicing the unit without appropriate personal protective equipment (PPE) may result in serious injury such as burns, rashes, eye, throat or lung damage and death. Always wear PPE as indicated in the Safety Data Sheet (SDS) when using or servicing the unit. Protect eyes, skin, and lungs against drifting spray.



Chemical solutions may pose a health risk and death if they contact the skin or eyes, are inhaled or swallowed. Always read and follow all chemical safety precautions and handling instructions provided by the chemical manufacturer and the SDS associated with the chemical solution before using the unit.



Pressure within the equipment may cause an unexpected release of the chemical solution and cause serious injury such as burns, rashes, eye damage, throat or lung damage and death. Always depressurize and clean the unit after each use. Never leave the unit unattended while pressurized.

Using the unit with fluid temperatures above 100°F (37.8°C) may result in scalding, burns, serious injury or death. DO NOT use a solution with a temperature above 100°F (37.8°C).

Operating the unit when damaged or leaking may result in exposure to chemical solutions, serious injury or death. Never use the unit if it is damaged or leaking.

Never point the discharge wand at yourself, another person, or any object you do not want covered in chemical.



Use of hydrocarbons and flammable products may result in explosions, fire and serious injury or death. Never use hydrocarbons or flammable products with the unit.



Mixing an alkaline with an acid may result in a chemical reaction. Overheating of the mixture may cause it to splatter caustic compounds or release hazardous fumes, gas and vapors. Always flush the unit with fresh water thoroughly when switching from an alkaline to an acid or an acid to an alkaline.

NOTICE

Servicing, or modification, of this unit with parts not listed in this manual may cause the unit to operate improperly. Do not use unauthorized parts when servicing the unit.

Only lift and carry unit by the carrying handle. Do not lift or carry the unit by the pump handle, hose, wand, or other components.

Do not use unit while pump handle is extended or not fully locked into position

PROTECT THE ENVIRONMENT



Please dispose of packaging materials, old machine components, and hazardous fluids in an environmentally safe way according to local waste disposal regulations.

Product Overview

Requirements

Liquid temperature range	40-100°F (4.4-37.8°C)
Chemical compatibility	Chemical products used with this equipment must be formulated for this type of application and compatible with unit materials and pump seals. For more information on chemical compatibility, consult the manufacturer or SDS for your product or contact our customer service department.

Specifications

	SP5.0L	SP5.0L-PSG
Power type	Manual	
Chemical pickup type	Draws from pre-mixed solution	
Number of products unit can draw from	One product	
Suction line length/diameter	11.5 in. (29.2 cm) clear poly tubing with 1/8 in. (3.2 mm) inner diameter	
Capacity	1.3 gallons (5 liters)	
Discharge line length/diameter	6.5 ft. (2 m) hose, with 1/4 in. (6.4 mm) inside diameter	
Discharge wand/tip type	Polypropylene trigger handle with 17 in. (43.2 cm) wand extension and 80° fan tip	Polypropylene trigger handle with 40° fan tip
Output distance*	3-5 ft. (0.9-1.5 m)	
Output volume*	0.2 gal/min (0.8 l/min)	0.3 gal/min (1.1 l/min)
Flow rate*	0.2 gal/min (0.8 l/min)	0.3 gal/min (1.1 l/min)
Pump seals	Viton	

*Rates given are based on chemical with viscosity of water and factory air pressure settings. These rates can vary based on viscosity of product and fan tip size.

Product Components

Get to know the components that you will need to use, adjust or assemble.

Pump-Up Spray Unit • 1.3 Gallon

1. Discharge wand
2. Trigger gun
3. Pressure relief valve
4. Discharge hose
5. Pump handle
6. Tank head
7. Solution tank

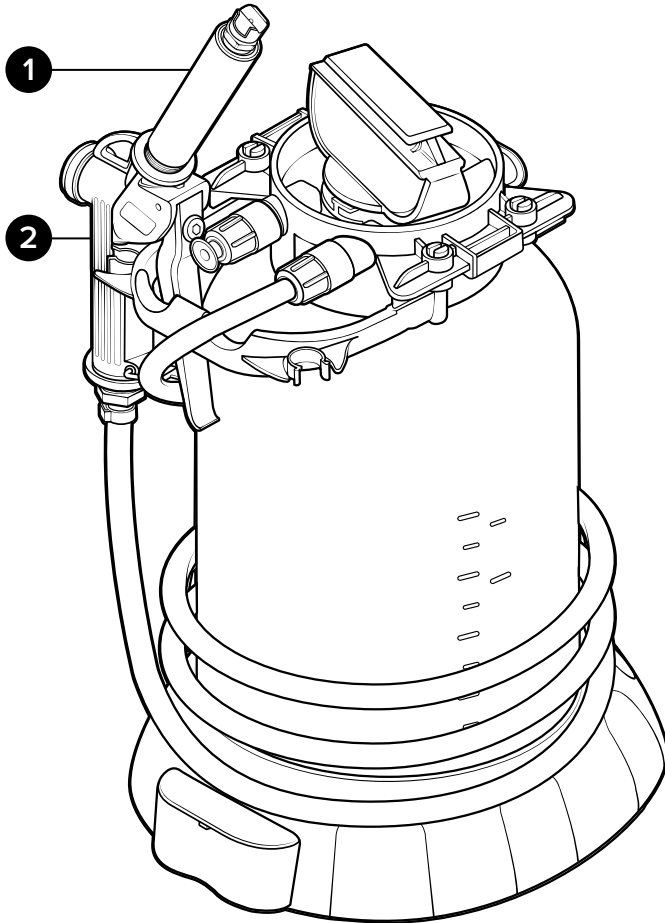

SP5.0L-PSG

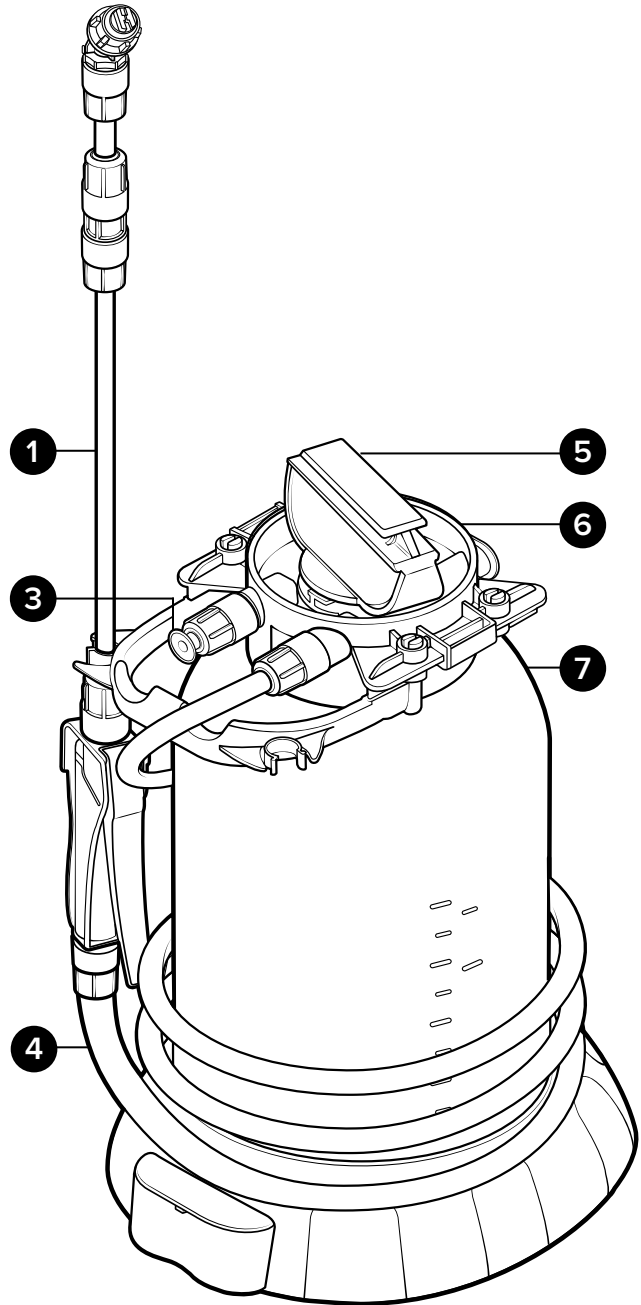

SP5.0L

Using your unit

Operating Instructions

1. Remove components from packaging.
2. For **SP5.0L**: Attach wand assembly to trigger handle.
For **SP5.0L-PSG**: Continue to step 3.
3. Pull the green pressure release valve until the red portion of the stem is showing to confirm the unit is not pressurized.
4. With the pump handle pressed fully down, hold the unit and unscrew the pump assembly from the tank head to access the filler hole.
5. Follow all instructions from the chemical manufacturer when filling the unit. Fill the tank $\frac{3}{4}$ full with pre-mixed solution. Do not overfill the tank.
6. With the pump handle pressed fully down, hold the unit and screw the pump assembly back into the tank head to close the unit.
7. To pressurize the tank, rotate the handle of the pump assembly until it is free then pump up the unit. The pressure relief valve will begin leaking air when the tank is fully pressurized.
8. Once the desired pressure has been achieved, push the pump handle down and rotate to lock it in place.
9. To begin spraying, point the discharge wand towards the area you wish to spray and squeeze the trigger handle. Release the handle to stop.

After Use Instructions

10. Release air pressure from unit after each use by activating the pressure relief valve.
11. Empty out remaining solution and run fresh water through the unit to rinse all parts thoroughly after each use and before storage.

Maintenance Instructions

To keep your unit operating properly, periodically perform the following maintenance procedures:

- Check the pump assembly for wear and leaks.
- Check the suction line for debris and clean as needed.
- Periodically lubricate the pump seal with food safe lubricant. To lubricate the pump seal, raise the handle of the pump assembly and apply 5-10 drops of food safe lubricant between the pump and pump sleeve.

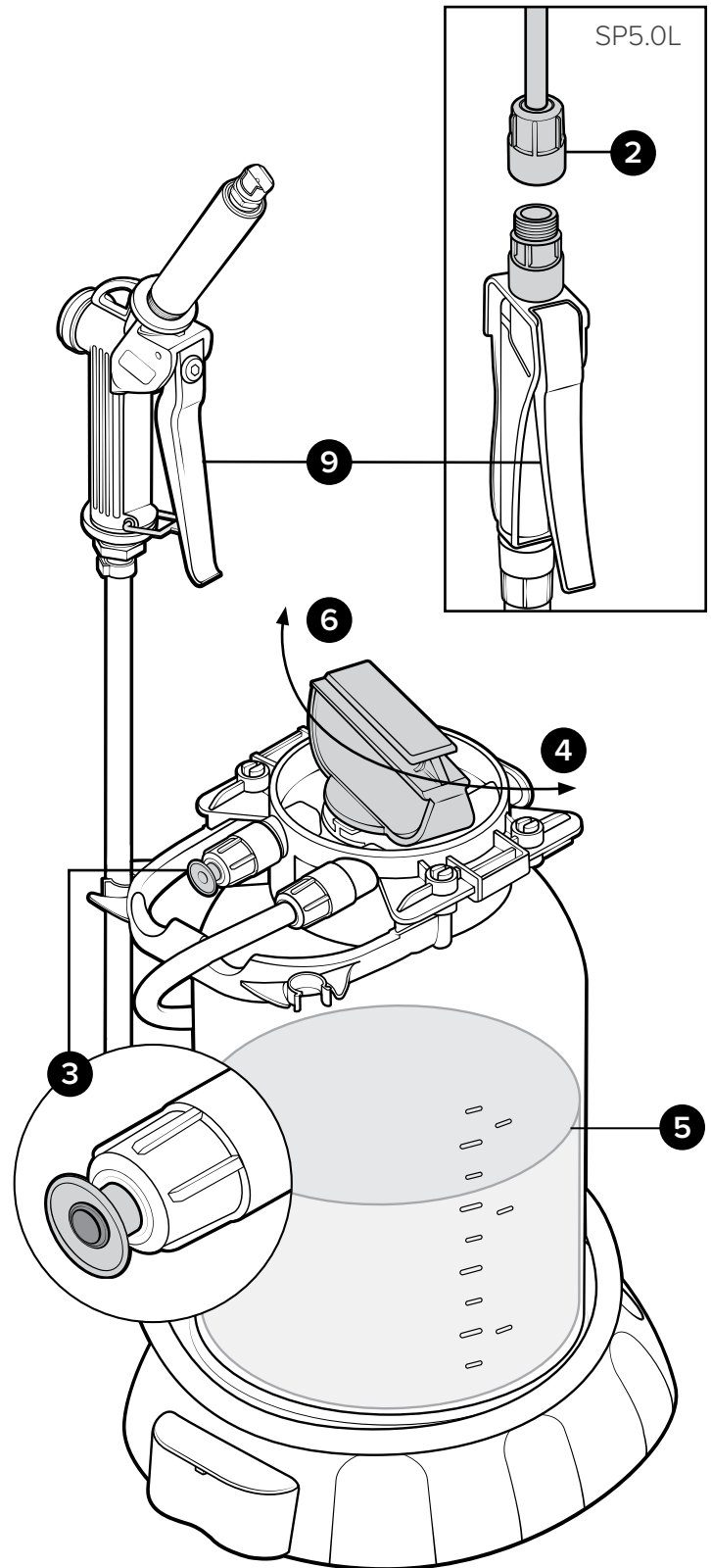

SP5.0L-PSG

Servicing your unit

SP5.0L

SP5.0L:

5 liter pump-up spray unit

LC-SLA-SP:

Short lance assembly - for 5L spray unit - includes spray tip, gasket, and retaining nut

Item number	Description
1 LC-SLA	Short lance (2 in.) assembly - no retaining nut, o-ring, spray tip
2 LC-WA-OR	O-ring for 5L / 10L wand assembly
3 STB8002	Spray tip - button style - 80 degree - 0.2 GPM
4 LC-WA-RN	Retaining nut for 5L / 10L wand assembly

Item number	Description
5 LC-LLA	Long lance (10 in.) assembly for 5L / 10L - with retaining nuts
6 LC-PRV	Pressure relief valve for 5L / 10L
7 LC-PSG	Poly spray gun for 5L / 10L - blue
8 LC-HA	Hose assembly for 5L / 10L
9 LC-PA	Manual pump assembly for 5L / 10L - Viton
10 LC-THA-SP5.0L	Tank head assembly for 5L spray unit - with pressure relief valve and tank handle
11 TANK5L	5 liter tank
12 LC-HNDL-CLP	Tank handle for 5L / 10L - with clips

LC-SLA-SP

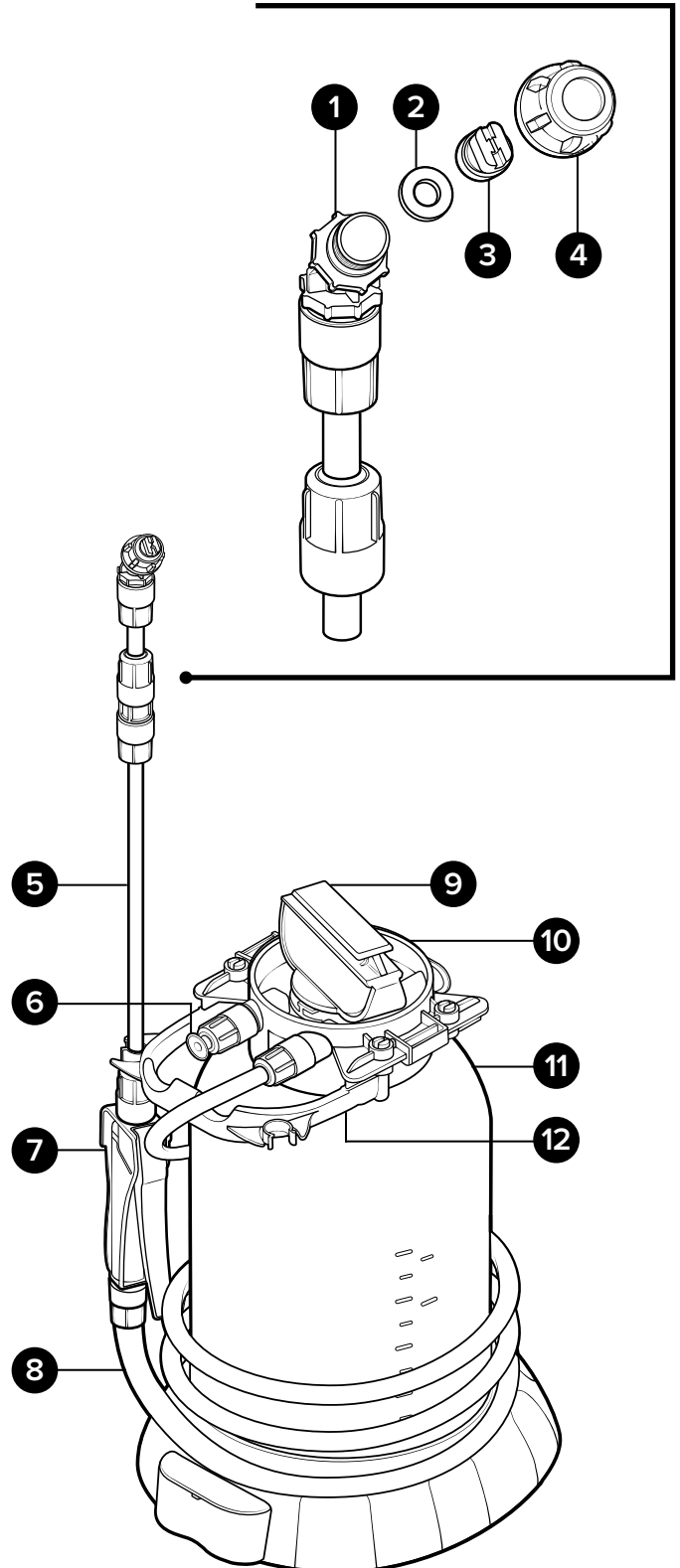

Servicing your unit

SP5.0L-PSG

SP5.0L-PSG:

5 liter pump-up spray unit with PSG trigger gun

PSGA144-ST4003:

Poly spray gun assembly for ¼ in. hose - includes 4 in. black poly wand, spray tip, hose barb, and screw band clamp

Item number	Description
1 ST4003SS	Spray tip - 80 degree - 2.0 GPM - stainless - ¼ MPT
2 PW12M14F4	1/2 in. NPT and ¼ in. FNPT wand - black UHMW - 4 in. long
3 PSGORV	O-ring for poly spray gun
4 PSG12	Poly spray gun with 2x ½ in. straight thread - gray handle with red clip - 316SS internal spring - includes 2x o-ring
5 HBSS1214	Stainless hose barb ½ MPT x ¼ barb
6 SSC14	Stainless screw band clamp for ¼ in. hose

Item number	Description
7 LC-PRV	Pressure relief valve for 5L / 10L
8 LC-PA	Manual pump assembly for 5L / 10L - Viton
9 LC-THA-SP5.0L	Tank head assembly for 5L spray unit - with pressure relief valve and tank handle
10 TANK5L	5 liter tank
11 LC-HNDL-CLP	Tank handle for 5L / 10L - with clips

PSGA144-ST4003

