

Airless Footwear Sanitizing Unit

Service Manual

SS4 | SS4-MBS | SS4-BSH

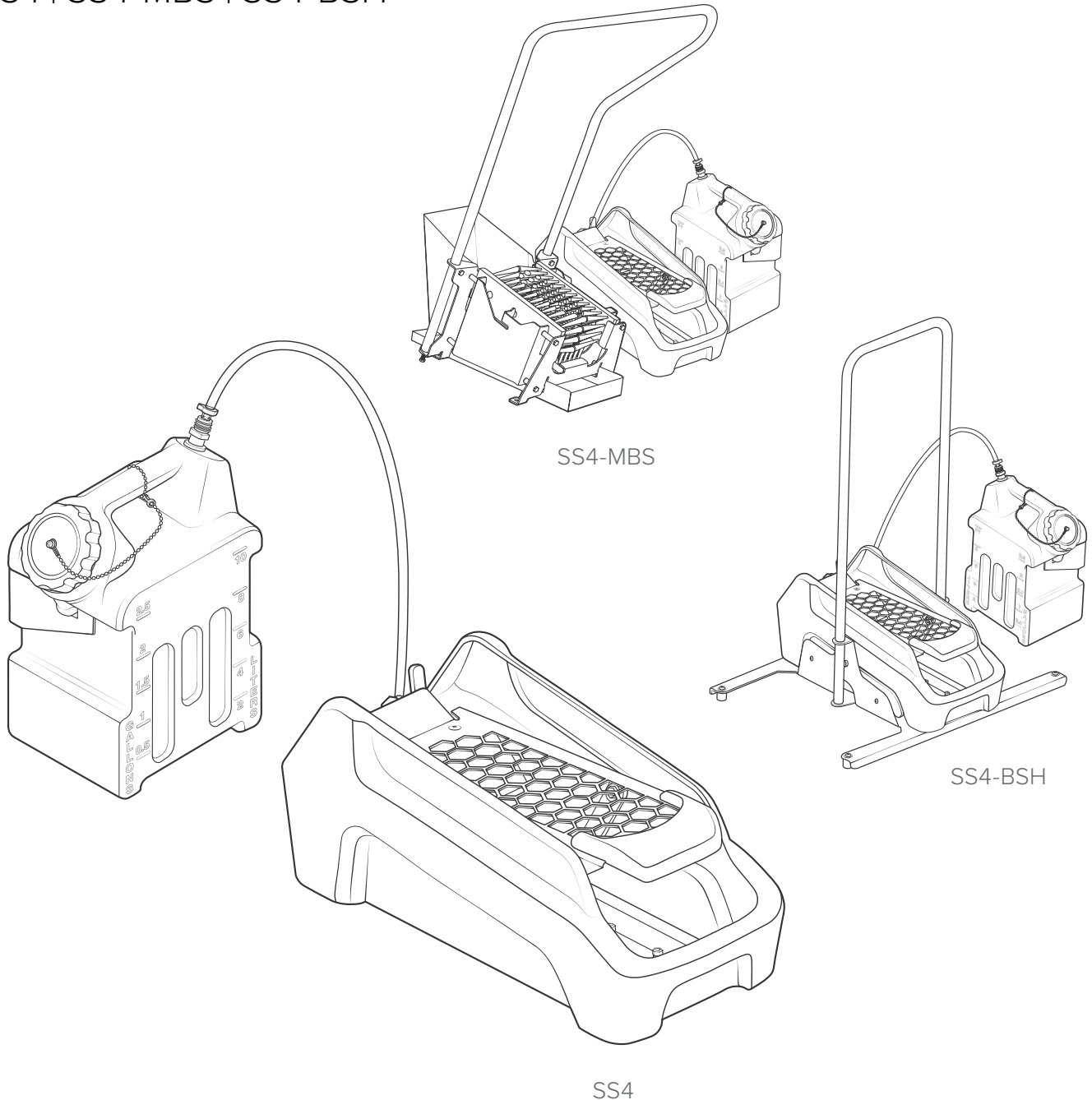

READ ALL INSTRUCTIONS BEFORE USING OR SERVICING THIS UNIT. KEEP THIS MANUAL IN A LOCATION THAT IS READILY AVAILABLE TO USERS AND SERVICE TECHNICIANS.

English (Original Instructions)



Scan this code for
service manual

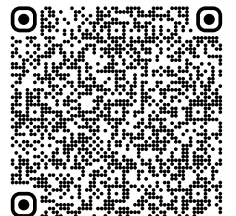

Safety

WARNING

PEOPLE OR OBJECTS CAN BE HURT OR DAMAGED IF THIS UNIT IS NOT USED CORRECTLY!



Failure to read all the instructions before operating the unit may result in personal injury or death from the improper use or chemical solution. Anyone handling, operating or using the unit must read and understand the instructions in the manual. The buyer assumes all responsibility for safety and proper use in accordance with the instructions.



Using or servicing the unit without appropriate personal protective equipment (PPE) may result in serious injury such as burns, rashes, eye, throat or lung damage and death. Always wear PPE as indicated in the Safety Data Sheet (SDS) when using or servicing the unit. Protect eyes, skin, and lungs against drifting spray.



To prevent chemical spray to face and eyes, ensure full foot insertion into unit and press down with heel. All protective gear must be worn as directed by the chemical manufacturer, SDS, and any applicable local safety regulations (OSHA, EU Directives, etc..)

This unit is for use with fully protective footwear only. This unit is designed to help sanitize footwear at transition zones with a focus on reduced moisture. This unit is intended to sanitize shoe soles and not intended for any other use.



Chemical solutions may pose a health risk and death if they contact the skin or eyes, are inhaled or swallowed. Always read and follow all chemical safety precautions and handling instructions provided by the chemical manufacturer and the SDS associated with the chemical solution before using the unit.



Pressure within the equipment may cause an unexpected release of the chemical solution and cause serious injury such as burns, rashes, eye damage, throat or lung damage and death. Always disconnect the air line from the unit before performing any maintenance, and clean the unit after each use.

Using the unit with fluid temperatures above 100°F (37.8°C) may result in scalding, burns, serious injury or death. DO NOT use a solution with a temperature above 100°F (37.8°C).



Operating the unit when damaged or leaking may result in exposure to chemical solutions, serious injury or death. Never use the unit if it is damaged or leaking.

Use of hydrocarbons and flammable products may result in explosions, fire and serious injury or death. Never use hydrocarbons or flammable products with the unit.

NOTICE

Servicing or modifying this unit with parts not listed in this manual may cause the unit to operate improperly. Do not use unauthorized parts when servicing the unit.

This unit is for use with fully protective footwear only.

PROTECT THE ENVIRONMENT



Please dispose of packaging materials, old machine components, and hazardous fluids in an environmentally safe way according to local waste disposal regulations

Service Guide

WARNING

Performing any maintenance with the unit pressurized may result in serious injury. Before conducting any maintenance, always ensure the unit has been depressurized by disconnecting the air line on the unit. Servicing or modifying this unit with parts not listed in this manual may cause the unit to operate improperly. Do not use unauthorized parts when servicing the unit. Remember to reconnect air line, and re-prime the unit according to the priming instructions in the operation manual after performing any maintenance.

Maintaining Your Unit

To keep your unit operating properly, perform the following daily maintenance procedures:

For SS4, SS4-BSH, and SS4-MBS units:

- Inspect the stainless foot grate for debris and clean when necessary.
- Collection basin should be emptied and cleaned each time the chemical supply container is changed or refilled. See **Collection basin cleaning instructions** for more information.

Note: During heavy use, over-spray can fill up basin. Be mindful of fluid levels not reaching above manifold, this can cause the unit to operate improperly.

- Verify nozzle assembly is free of any debris or blockage. Rinse with low pressure water if necessary.
- Check suction line and strainer for debris. Clean as needed.
- Inspect all tubing for leaks or excessive wear. Make sure all hose clamps and push fittings are in good condition and properly secured.

For SS4-MBS units only:

- Remove brushes by lifting them out from the brush bracket. Remove debris and clean. Brushes should be replaced every 6 months depending on wear.
- Slide out debris tray. Empty debris and wipe clean.
- Base assembly of unit is fully stainless and can be cleaned in place by method suitable for stainless steel.

Collection basin cleaning instructions:

1. Turn Lock Lever to the unlock position
2. Holding the mechanism by its touch points, slide the mechanism over to the right, lift up, and towards you to disengage the hooks
3. Place mechanism aside, level with the floor.
4. Empty and clean the collection basin.
5. Re-insert the mechanism by repeating step 2 in reverse order.
6. Slide the lock lever until it is upright and/or tab is touching the mechanism, as shown below.

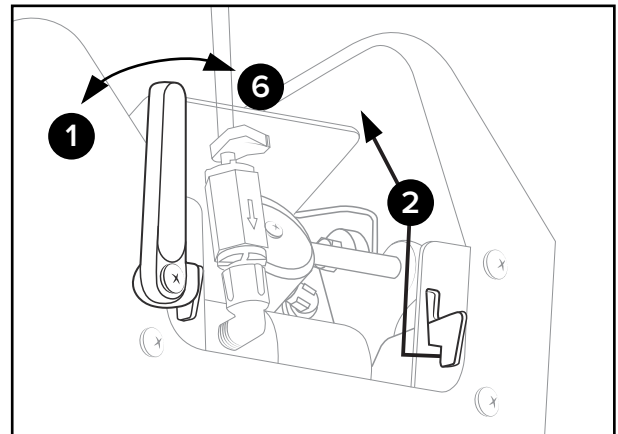

Servicing Your Unit

Most repairs on the unit can be performed with the following tools:

- Crescent wrench (2x)
- $\frac{7}{16}$ in. (11 mm) socket wrench
- $\frac{9}{16}$ in. (14 mm) socket wrench
- #3 Phillips head screwdriver
- Thread seal tape
- Hose cutters
- Knife

Troubleshooting Your Unit

If your unit is not operating properly, try using these troubleshooting tips:

Issue	Solution
If unit does not spray	<ul style="list-style-type: none">• Check if you hear exhaust from the air valve. If not, manually press the stem button and see if it is stuck. Replace as needed.• If the pump is cycling, but unit does not spray, the pump may be air locked.• Check the suction line and strainer for debris and clean if necessary.• Verify springs in the air pump and/or liquid pump are not broken.• Check that the jug the unit is pulling from is vented, and filled appropriately.• Ensure nothing is blocking or impeding the full motion of the mechanism.
If unit sprays irregularly	<ul style="list-style-type: none">• Verify the pumps are cycling regularly. Pumps can be disassembled and the o-rings can be re-lubricated with a silicone-based lube.• Ensure the springs in the air pump and/or liquid pump are not broken.• Check the spray tips and make sure they are not clogged or blocked by debris. The spray tips may be removed and cleaned if necessary.• Verify that the jug the unit is pulling from is vented, and filled appropriately.
If unit does not hold a prime	<ul style="list-style-type: none">• Check hose clamps and ensure that barbs are secure.• Check all tubing connections and verify none are loose, broken, or leaking.

Housing Assembly

SS4

HSGA-SS4:

Housing assembly for SS4 - includes mechanism mounting plate, lock lever, rubber feet, locknuts and bolts

Item number	Description
1	LN1420 Locknut - ¼-20 - stainless - nylon insert
2	HSG-SS4 Housing for SS4
3	LKLVR-SS4 Lock lever for SS4
4	B1420112 Bolt - ¼-20 x 1 ½ in. - stainless steel truss head Phillips
5	MPL-SS4 Mount plate for SS4
6	B142058-VS ¼-20 x 5/8 in. bolt - stainless - truss head Phillips - Vibra-Seal
7	RFT12 Rubber foot - ½ in. tall - includes internal washer

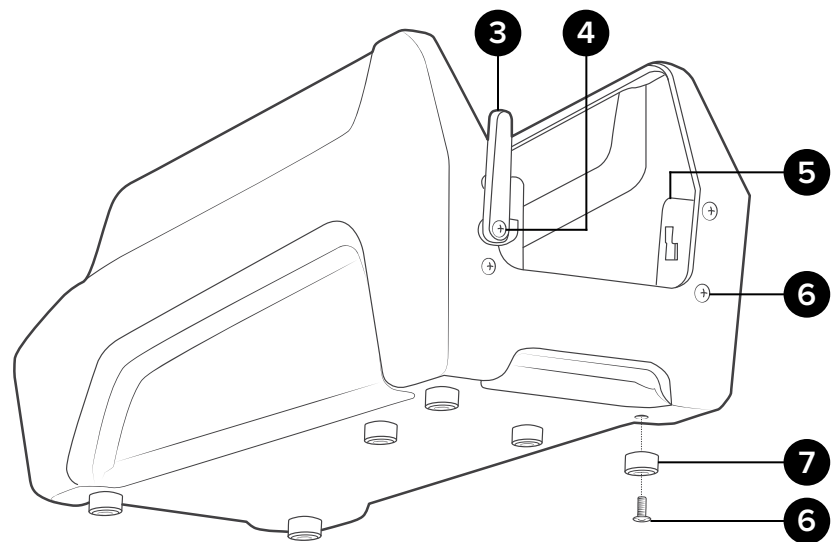
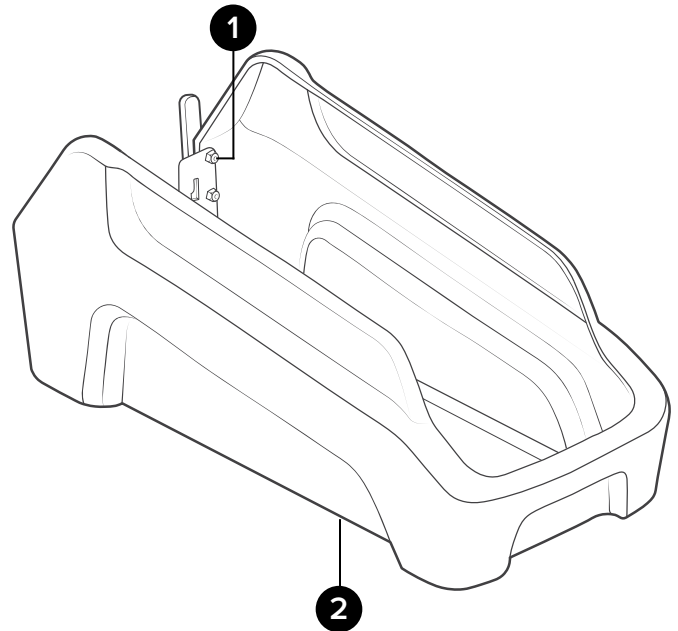
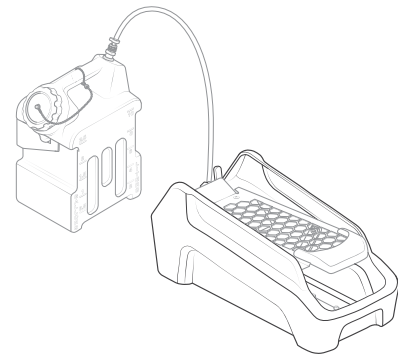

HSGA-SS4

Mechanism Assembly

SS4

MCHA-SS4:

Mechanism assembly for SS4 - includes fluid and air pumps, foot locator, manifold assembly, and mounting hardware

Item number	Description
1	B142012-VS ¼-20 x ½ in. bolt - stainless - truss head Phillips - Vibra-Seal
2	H14CL-PV ¼ in. id ¾ in. od clear hose - PVC - available per ft.
3	CLMPTB38-ADJ Clamp for ¼ in. od tube - plastic - adjustable
4	GRTA-SS4 Grate assembly - SS4 - includes foot locator and mounting screws
5	SPGRD-SS4 Spray guard for SS4
6	B3816612-HH ¾-16 x 6.5 in. bolt - stainless - hex head
7	MNA-SS4 Manifold assembly - SS4 - includes SS misting nozzles, fitting, and plug
8	LN3816 Locknut - ¾-16 jam - stainless - nylon insert
9	LN1420 Locknut - ¼-20 - stainless - nylon insert
10	CV14HB14M Check valve - PVC - ¼ barb x ¼ MNPT - 302SS spring - Viton seals - air flow right
11	PMPA-AIR-SS4 Pump assembly - SS4 - air - includes spring and seals
12	B3816712-HH ¾-16 x 7.5 in. bolt - stainless - hex head
13	BSH14201316-HH-VS ¼-20 x 1¾ in. shoulder bolt stainless - hex head - Vibra-Seal
14	LNKG-CHS-SS4 Linkage chassis - SS4 - stainless steel
15	PMPA-FLD-SS4 Pump assembly - SS4 - fluid - includes spring and seals

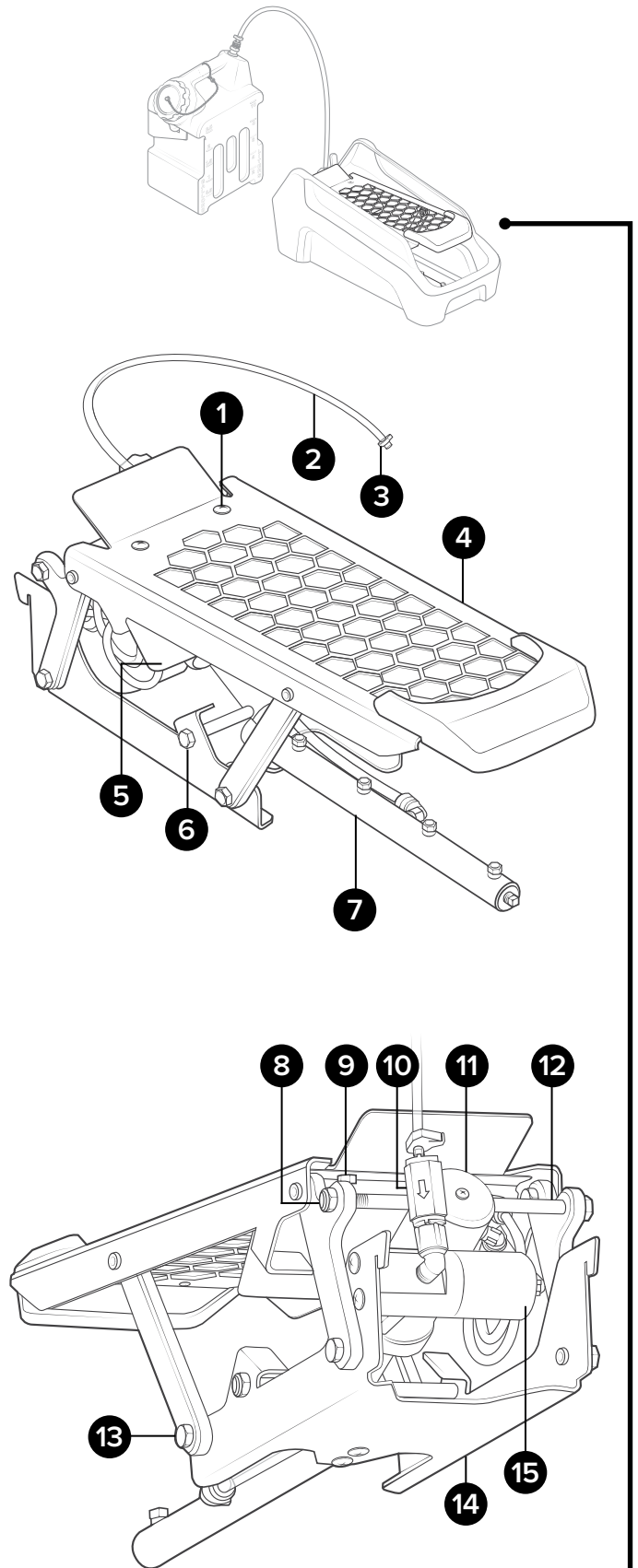

MCHA-SS4

Mechanism Sub-assemblies

MNA-SS4:

Manifold assembly for SS4 - includes SS misting nozzles, fitting, and plug

Item number	Description	
1	MN-SS4	Manifold - SS4 - 1/8 in. NPT - 6 ports PVC
2	QFEL1438	Fixed elbow 1/4 in. MPT x 3/8 in. tube - polypropylene
3	FCMNSS804	Full cone misting nozzle - stainless 80 deg - 4 GPH
4	P18	Plug 1/8 MPT hex head 304 SS

VLVA-3W2P-SS4:

Valve assembly for SS4 - 3 way 2 position - includes fittings and nut

Item number	Description	
5	QFEL1814	Fixed elbow 1/8 in. MPT x 1/4 in. tube polypropylene
6	QF1814	Quick fit - 1/8 MPT x 1/4 od tube - polypropylene
7	ACVB-3W2P	Air control valve - nickel-plated brass - 3 way 2 position - valve only - does not include tooth washers and nuts
8	N153232-SS4	Nut - 15/32-32 - stainless - for SS4

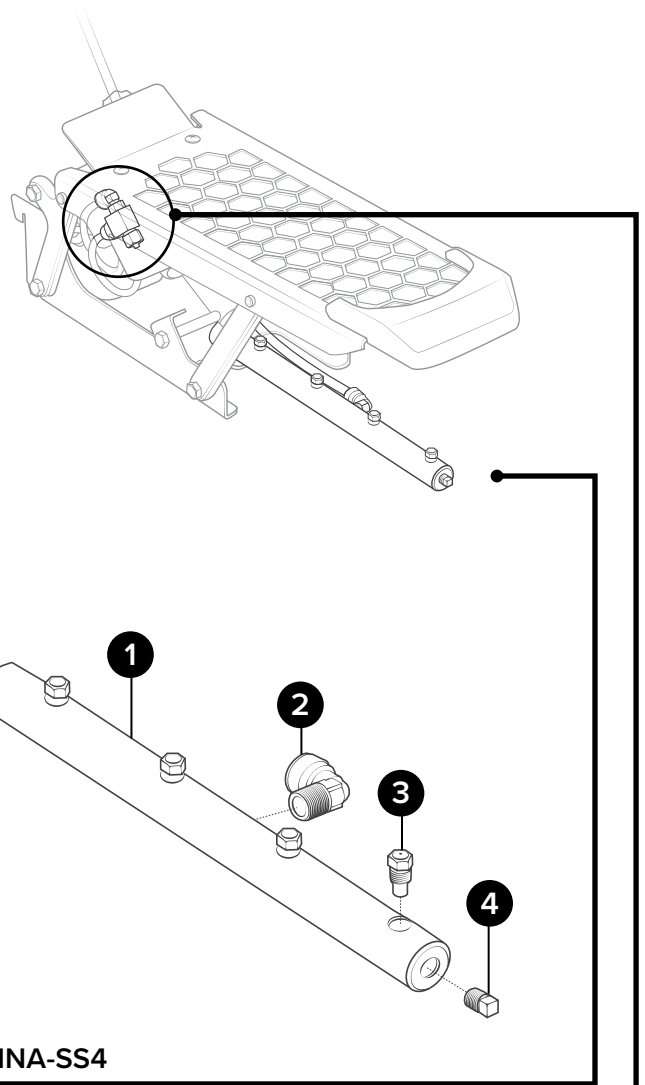

MNA-SS4

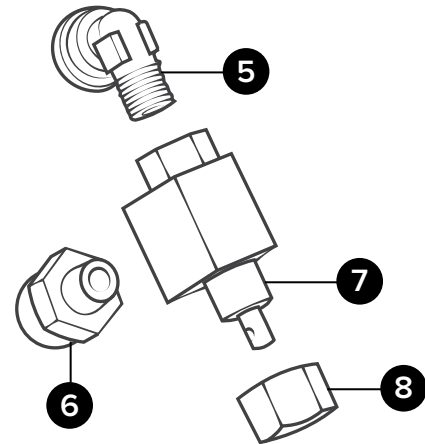

VLVA-3W2P-SS4

Mechanism Sub-assemblies

PMPA-FLD-SS4-WF:

Pump assembly for SS4 - fluid - includes fittings, tubing, and check valves

Item number	Description
1	CLMPTB38-ADJ Clamp for ¼ in. od tube - plastic adjustable
2	H14CL-PV ¼ in. id ¾ in. od clear hose - PVC - available per ft.
3	CV14HB14M Check valve - PVC - ¼ barb x ¼ MNPT - 302SS spring - Viton seals - air flow right
4	EL14M14F ¼ FPT x ¼ MPT - polypro elbow
5	QFEL1814 Fixed elbow ⅛ in. MPT x ¼ in. tube - polypropylene
6	CV14M14HB Check valve - PVC - ¼ MNPT x ¼ barb - 302SS spring - Viton seals - air flow left
7	PMPA-FLD-SS4 Pump assembly - SS4 - fluid - includes spring and seals
8	TB14BL-PU ¼ in. od blue tube - polyurethane - available per ft.

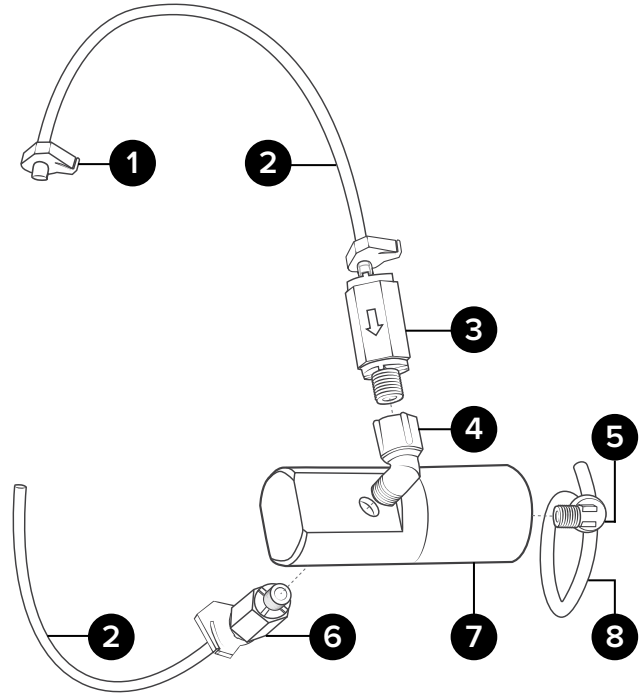
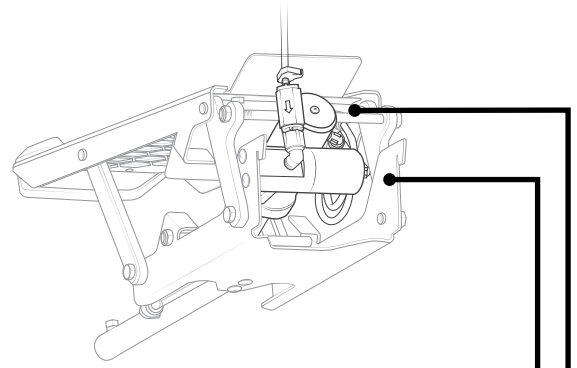

PMPA-FLD-SS4-WF

PMPA-AIR-SS4-WF:

Pump assembly for SS4 - air - includes fittings, tubing and quick fit elbow

Item number	Description
9	PMPA-AIR-SS4 Pump assembly - SS4 - air - includes spring and seals
10	B103214 10-32 x ¼ in. bolt - stainless - truss head Phillips
11	QFEL1814 Fixed elbow ⅛ in. MPT x ¼ in. tube - polypropylene
12	TB14BL-PU ¼ in. od blue tube - polyurethane available per ft.

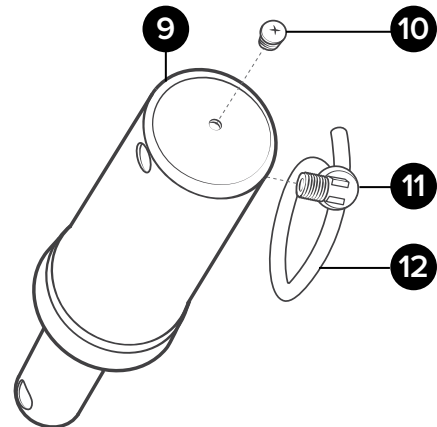

PMPA-AIR-SS4-WF

Base With Handle

SS4-BSH

SS4-BSH:

Footwear sanitizer - airless - SS4 - includes base with handle, 2.5 gallon chemical jug with suction, and SS rack

BSHA-SS4:

Base and handle assembly for SS4 - includes floor base plate, handle, and hardware

Item number	Description
1	B5161812-PH-VS 5/16-18 x 1/2 in. bolt - stainless pan head Phillips - Vibra-Seal
2	FW3816 Flat washer for 3/8-16 bolt - stainless - 0.41 in. id x 0.88 in. od x 0.05 in. thk
3	RFT1-516 Rubber foot - 1 in. tall - 5/16-18 threaded brass insert
4	B5161834-HH 5/16-18 x 3/4 in. bolt - stainless - hex head
5	B1420114-PH 1/4-20 x 1 1/4 in. bolt - stainless - pan head Phillips
6	LN516 Locknut - 5/16-18 - stainless - nylon insert
7	SPC34X34-PE Spacer - 3/4 in. od x 3/4 in. long for 1/4-20 bolt - LDPE
8	HNDL-FS Handle bar - footwear sanitizer - stainless steel
9	LCTR-SS4-BSPL-RH Locator - SS4 baseplate - RH
10	LCTR-SS4-BSPL-LH Locator - SS4 baseplate - LH
11	BSHPL-SS4 Base plate for SS4 and handle - stainless steel

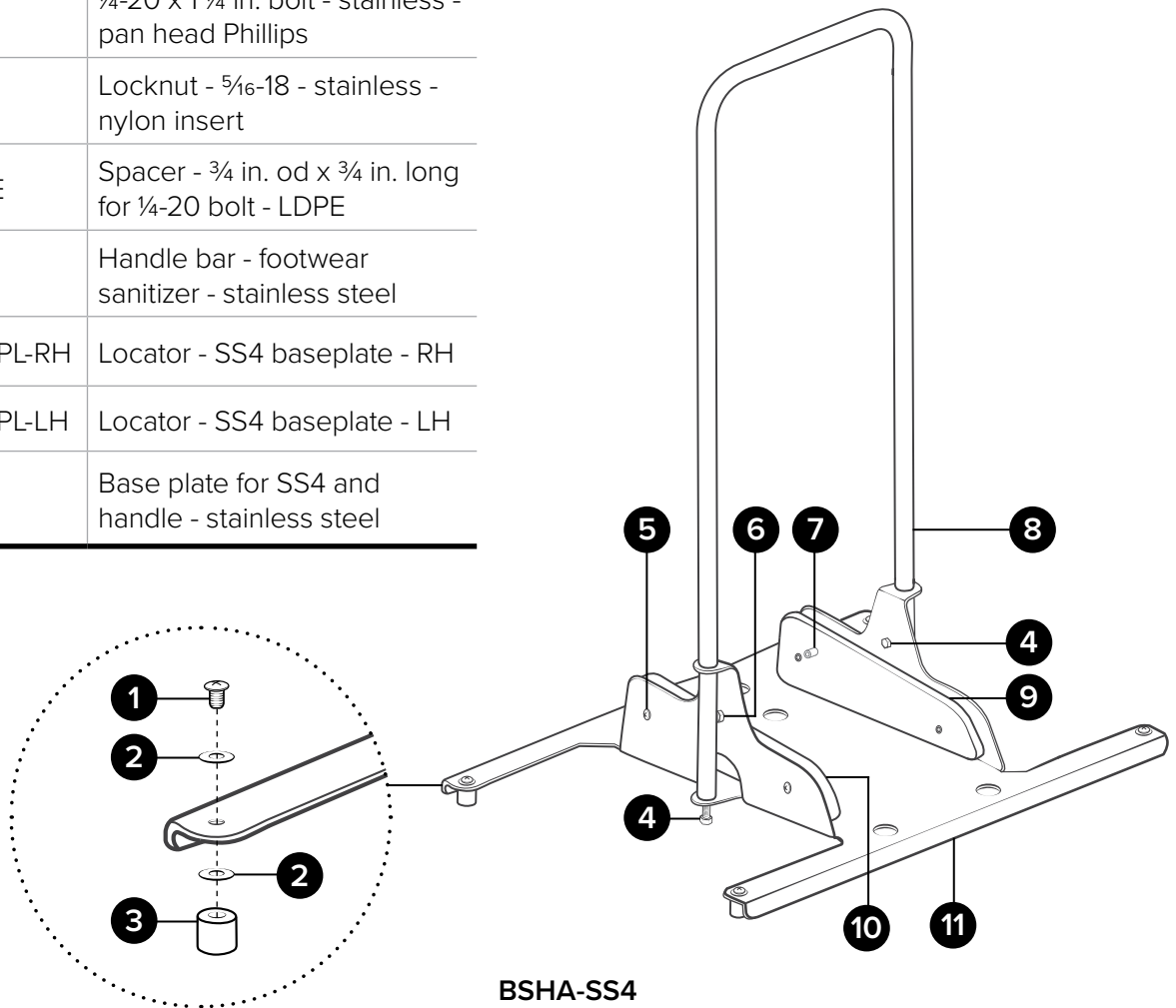
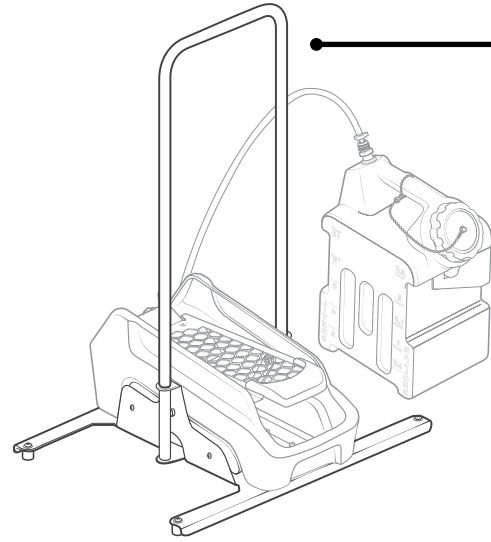

BSHA-SS4

Manual Boot Scrubber

SS4-MBS

SS4-MBS:

Footwear sanitizer - airless - SS4 - includes floor mount, manual boot scrubber with combo handle, 2.5 gallon chemical jug with suction, and SS rack

FMPL-SS4:

Floor mount plate for SS4

Item number	Description
1	FMPL-SS4 Floor mount plate for SS4 - stainless steel

MBS-C:

Manual boot scrubber with combo handle

Item number	Description
2	HNDL-FS-C Handle bar - footwear sanitizer and manual boot scrubber combo - stainless steel
3	DBSH Sebris shield for manual boot scrubber - stainless steel
4	LN516 Locknut - 5/16-18 - stainless - nylon insert
5	B5161834-HH 5/16-18 x 3/4 in. bolt - stainless - hex head
6	MBS100-C-BASE Manual boot scrubber floor mount bracket - footwear sanitizer base - stainless steel includes 2x B5161834-HH and LN516
7	BR10S Block brush for boot scrubber side - polypropylene
8	BR10 Block brush for boot scrubber sole - polypropylene
9	DBTR Debris tray for manual boot scrubber - stainless steel

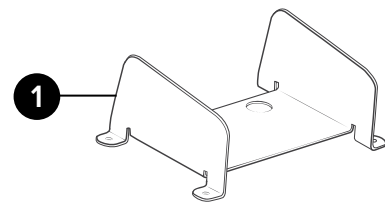
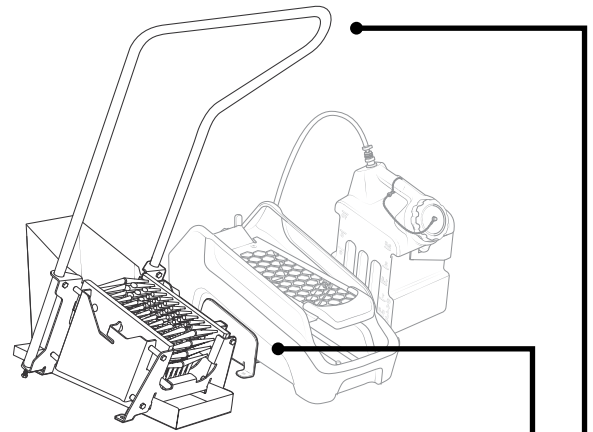

FMPL-SS4

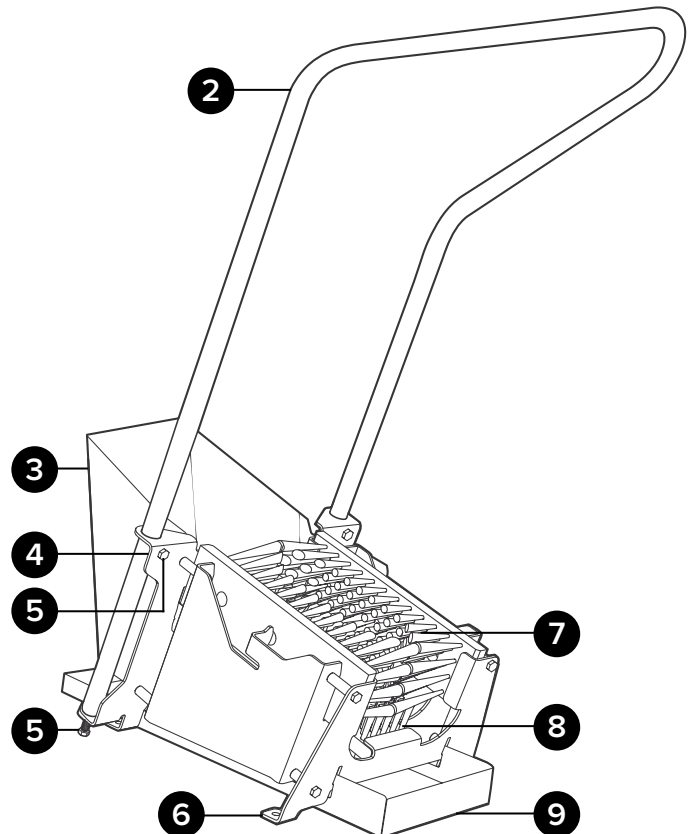

MBS-C

Jug Assembly

J2.5BKSr:

2.5 gallon natural jug - includes black cap, suction and SS rack

JC35B-TAV:

Black 3.5 inch one way vented cap polypropylene - includes EPDM gasket, check valve, and bead chain tether assembly

Item number	Description
1	B103234-SH-VNT 10-32 x 3/4 in. bolt - stainless - socket head - vented
2	JC35B-P Black 3.5 inch cap - polypropylene
3	CHN-JC35 JC35 bead chain tether assembly
4	CV-JC35 EPDM check valve for non locking jug cap
5	JC-G35 Jug cap gasket 3.5 inch cap EPDM

Item number	Description
6	J2.5 2.5 gallon natural jug - jug only

J2.5-SR:

Suction valve assembly for 2.5 gallon jugs

Item number	Description
7	P203CT-FS Foot strainer for the P203CT
8	H14CL-PV 1/4 in. id 3/8 in. od clear hose - PVC - available per ft.
9	TB14N-PE 1/4 in. od natural tube - polyethylene available per ft.
10	H38CL-PV 3/8 in. id 3/8 in. od clear hose - PVC - available per ft.
11	QCPP-M-HAST 3/8 in. panel mount socket - suction 3/8 id x quick connect - Hastelloy spring - 1/16-24 thread
12	QCPP14HB-HAST 1/4 in. in-line hose barb - polypro body - Hastelloy spring

SSJR2:

SS rack to mount chemical jug - includes mounting hardware

Item number	Description
13	WMS14 #14 x 1 1/4 in. wall mount screw - stainless hex head slotted
14	SSJR2-P SS rack to mount chemical transport jug
15	WMS14A #14 x 1 1/4 in. wall mount screw anchor - plastic - 5/16 in. drill size

JC35B-TAV

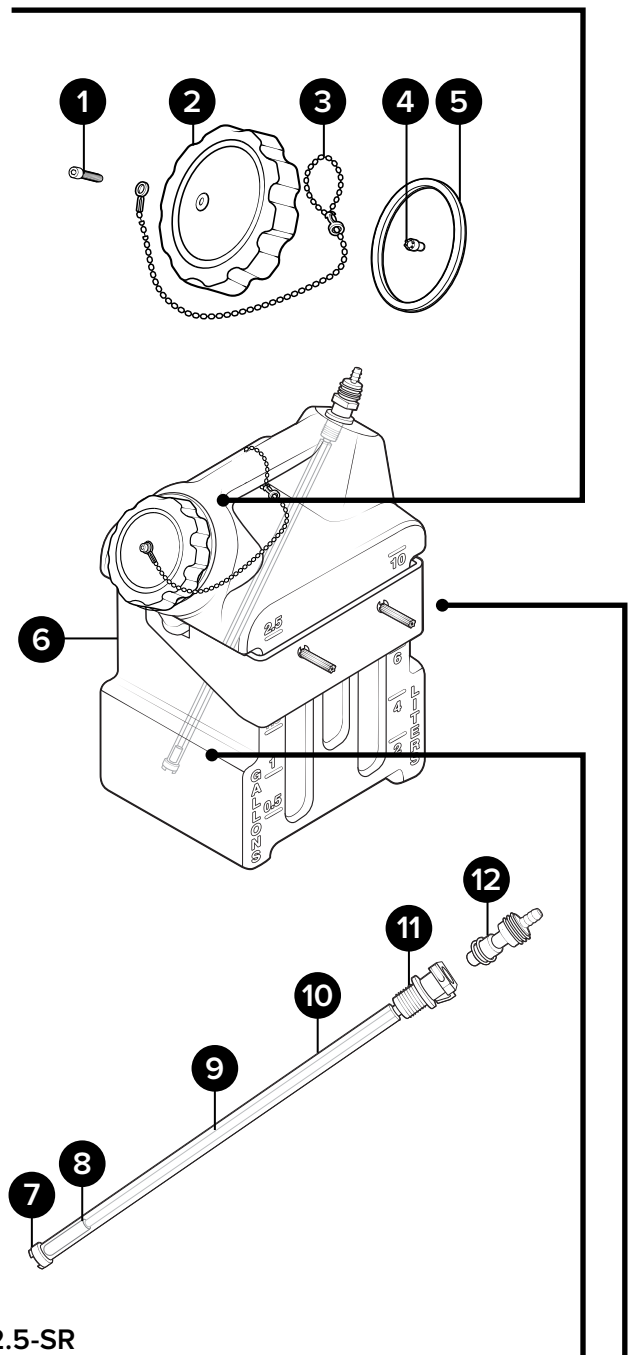

J2.5-SR

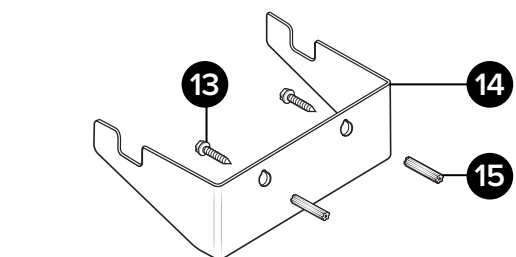

SSJR2

Additional Configurations

SS4-FM:

Footwear sanitizer - airless - SS4 - includes floor mount, 2.5 gallon chemical jug with suction, and SS rack

Item number	Description
1 SS4	Footwear sanitizer - airless - includes 2.5 gal chemical jug with suction and SS rack
2 FMPL-SS4	Floor mount plate for SS4

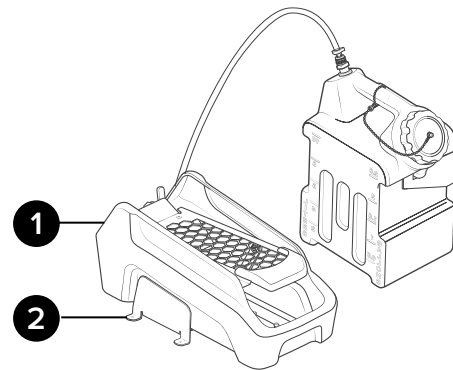

MBS:

Manual boot scrubber with handle

Item number	Description
3 HNDL-FS	Handle bar - footwear sanitizer - stainless steel
4 DBSH	Debris shield for manual boot scrubber - stainless steel
5 LN516	Locknut - 5/16-18 - stainless - nylon insert
6 B5161834-HH	5/16-18 x 3/4 in. bolt - stainless - hex head
7 MBS100-C-BASE	Manual boot scrubber floor mount bracket - footwear sanitizer base stainless steel - includes 2x B5161834-HH and LN516
8 BR10S	Block brush for boot scrubber side polypropylene
9 BR10	Block brush for boot scrubber sole polypropylene
10 DBTR	Debris tray for manual boot scrubber - stainless steel

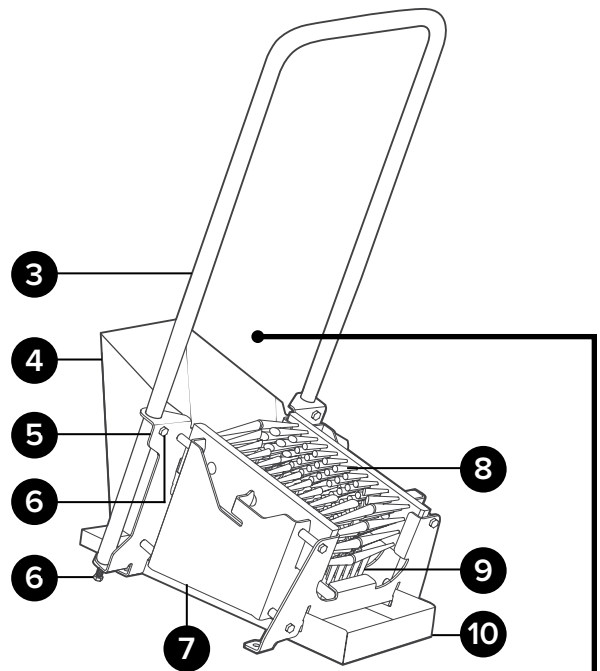

Optional Component

DBSH-EXT:

Debris shield extension for manual boot scrubber - stainless steel

Item number	Description
11 DBSH-EXT	Debris shield extension for manual boot scrubber - stainless steel

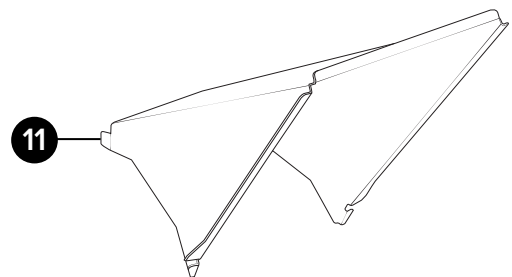

DBSH-EXT

**Optional component sold separately*